

FLEXIGLASS



1.15A - LDV T60 CANOPY FITTING MANUAL

SAFETY EQUIPMENT	ATECO PART NUMBER:	MATERIALS & PARTS REQUIRED	
• Hearing protection as required	*LV586-A001	Description	Qty.
• Eye protection as required	*LV586-B002	Canopy	1
	*LV586-K003	Clamps	8
	*LV586-F081	Wiring Set	1
	*LV586-M001	Tape	1.6m
		Bulb Seal	1.5m
		PVC Tube	2m

TOOLS REQUIRED

- Pneumatic/Electric driver
- Hole saw
- Angle grinder
- Allen keys

GENERAL NOTES

- Please read the fitting instructions prior to fitting the accessory.
- Install this accessory by following these fitting instructions. Please Note: Failure to follow these fitting instructions could result in damage to the vehicle and / or accessory.
- Recycle discarded components and packaging in accordance with the local regulations.
- Inspect the vehicle and note any damage or concerns found prior to accessory fitment. If there are any concerns contact the manufacturer before installing the accessory.
- If any damage or concerns are found that may interfere with the installation of the accessory, inform the customer prior to fitting the accessory.
- Ensure that you take care of and safely store any components that are removed from the vehicle.
- Ensure all bare metal surfaces are protected using an automotive bare metal primer and touch-up paint or suitable soft seal compound with rust inhibitor.
- Ensure any metal swarf or dust is carefully removed from all vehicle surfaces.
- Do not make any repairs or modifications to this accessory as it will void the warranty.
- Do not remove any of the accessory's labels.

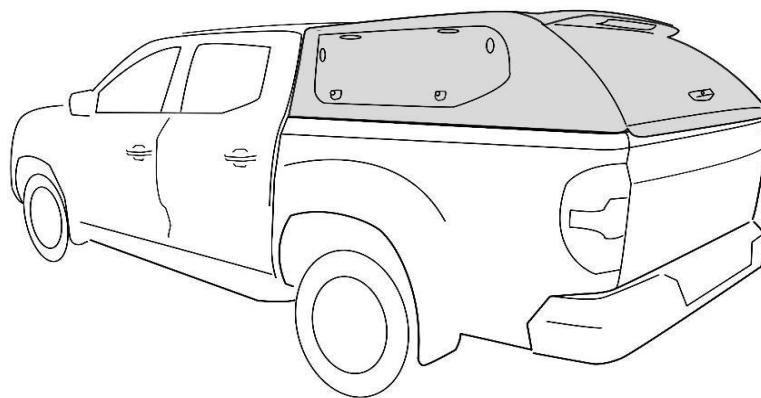

240 Min

	CANFSLDV	ISSUE 1	10/04/2019	Page No : 1/11
---	----------	---------	------------	----------------

1

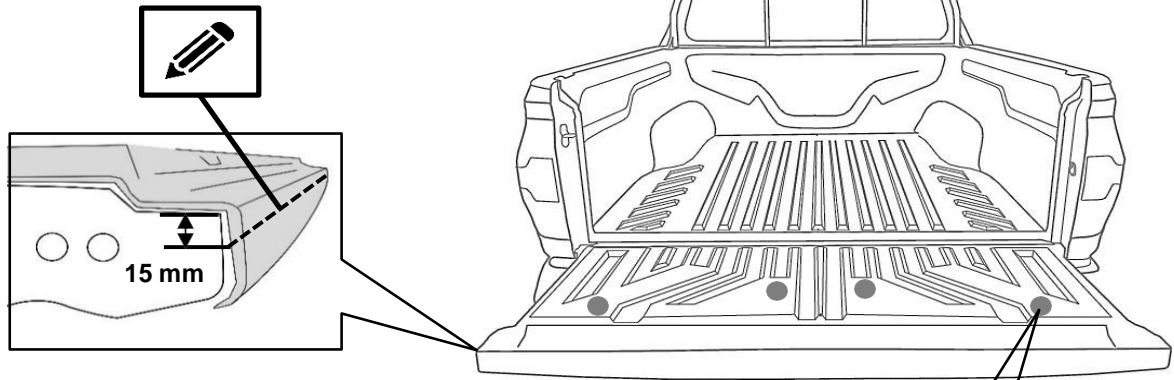

- Mark a straight line along the tailgate liner.
- Remove the lids and the bolts on the tailgate liner.

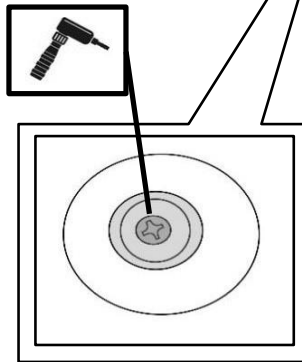

2

- Remove the bolts on the ute liner.
- Then, remove the ute liner.

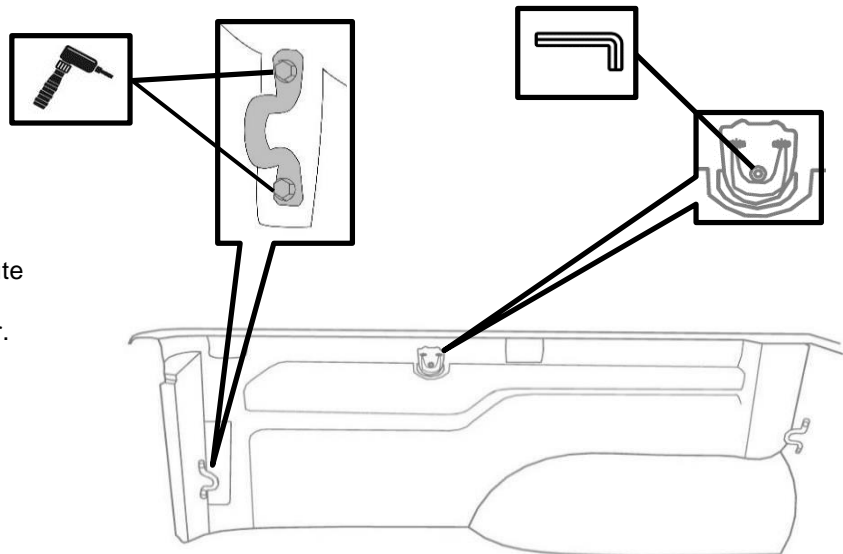

CANFSLDV

ISSUE 1

10/04/2019

Page No : 2/11

3



- Mark a line along the edge of the ute liner.
- Trim the edge of the ute liner.
- Use file to deburr the cut edge.

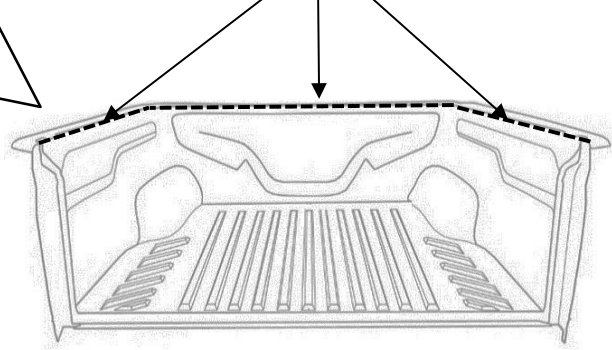
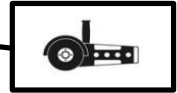
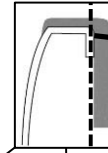
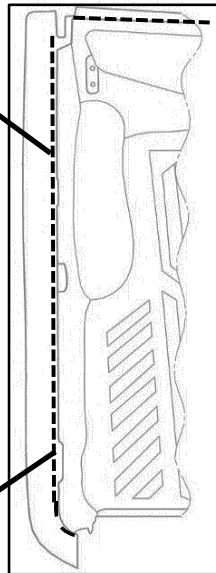
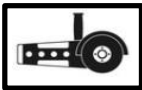

- Measure the hole positions from front face of the stepdown.
- Use 46mm hole saw to drill the holes.

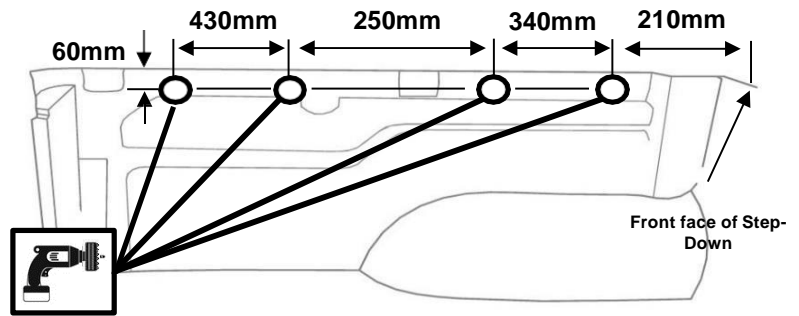

REAR

FRONT



4

- Trim the tailgate liner by following marked line.
- Use file to deburr the tailgate liner.

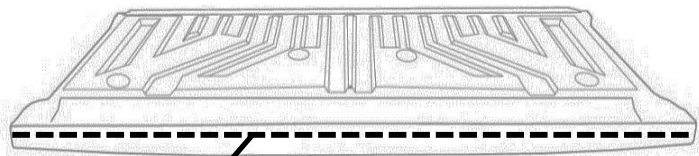
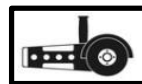

CANFSLDV

ISSUE 1

10/04/2019

Page No : 3/11

5

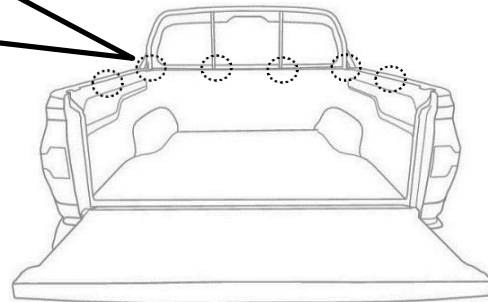
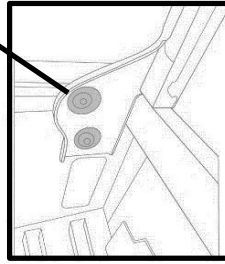

- Remove the bolts on the headbord/sports bar.
- Then, remove the headboard/sportsbar.



6

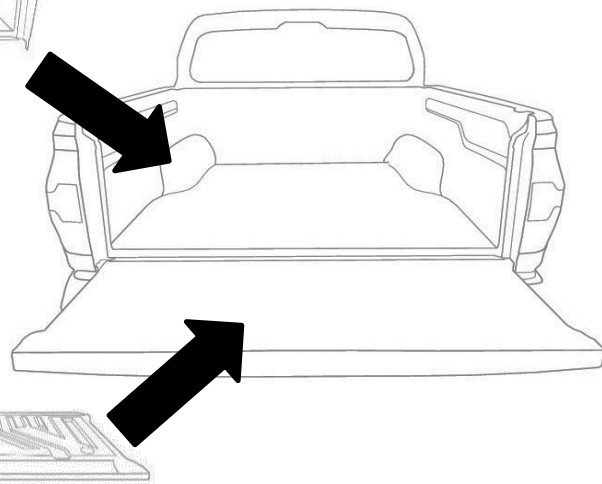
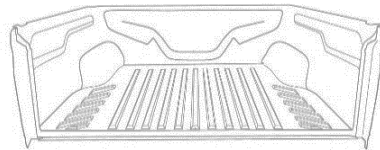

- After removing headboard/sportsbar, place ute liner and tailgate liner.
- Assembly is the reverse of the reassembly procedure.



7

- Measure the tailgate liner width and cut required amount (~1415 mm) of Bulb Seal.
- Fit Bulb Seal to the cut edge of the tailgate liner.

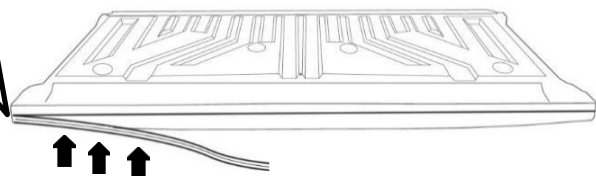
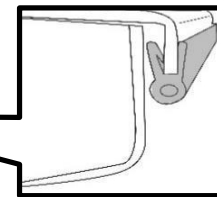
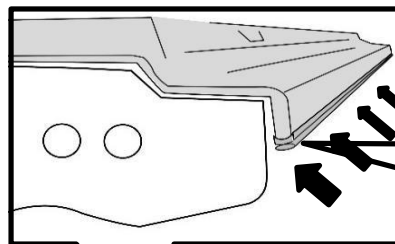

CANFSLDV

ISSUE 1

10/04/2019

Page No : 4/11

8

- Place the canopy on tub.

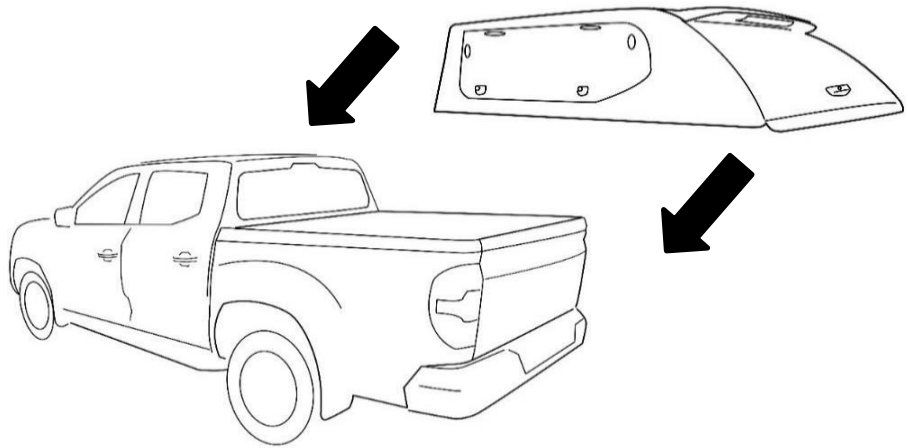

9

- Align canopy with front face of the tub.

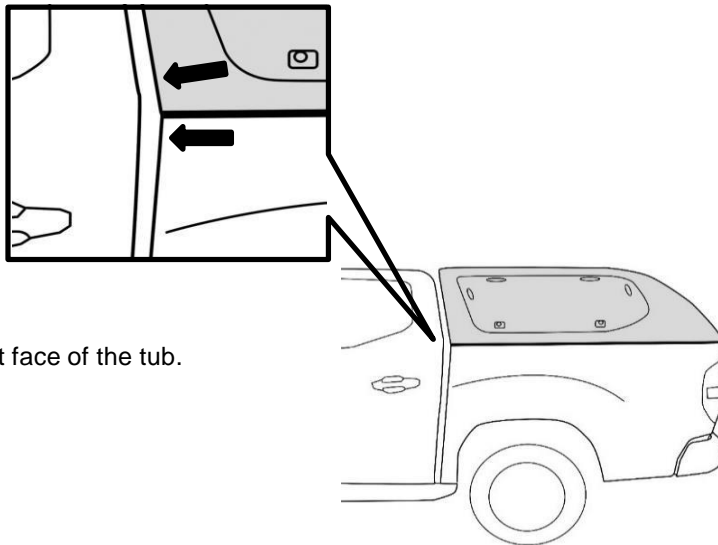

10

- Align canopy by checking tailgate outer edges on both sides.

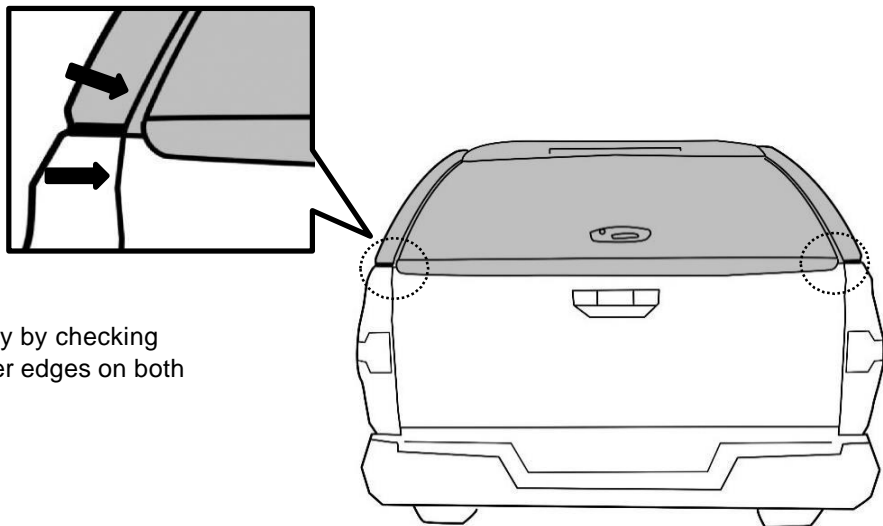

CANFSLDV

ISSUE 1

10/04/2019

Page No : 5/11

11

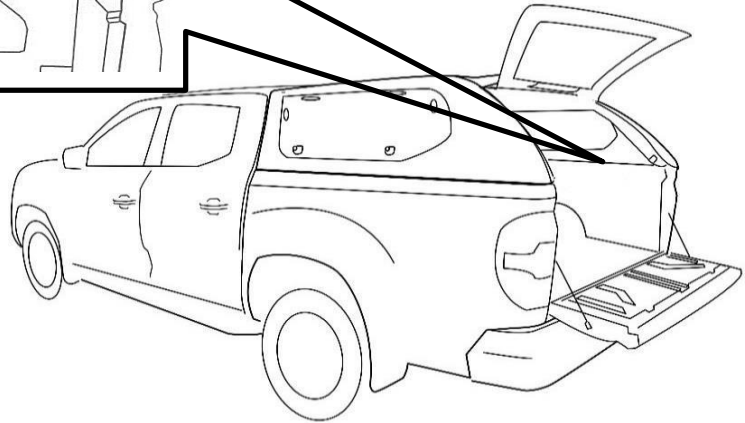
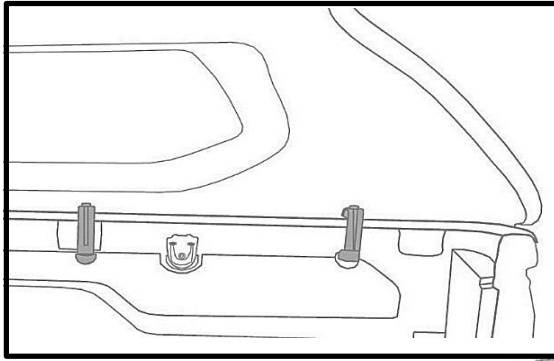

- Fit the clamps by using drilled holes on ute liner.



12

WIRING INSTRUCTIONS

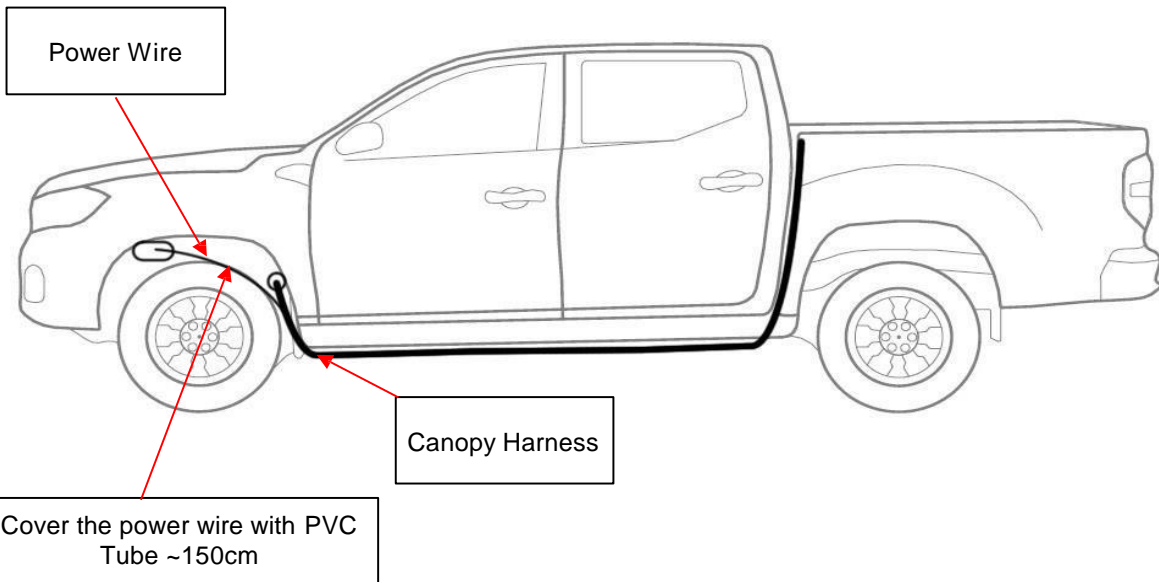

CANFSLDV

ISSUE 1

10/04/2019

Page No : 6/11

13

- Remove the wheelarch of the passenger side front tyre.

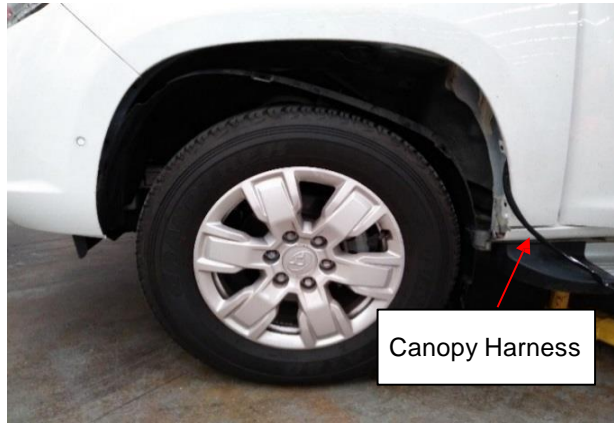

14

- Run canopy harness through the hole. (As shown in the line drawing above - Step 12)

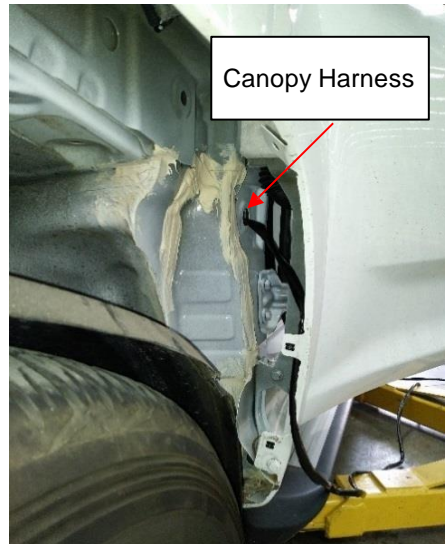

15

- On the passenger side (left hand) of the vehicle remove the scuff panel and kick panel.

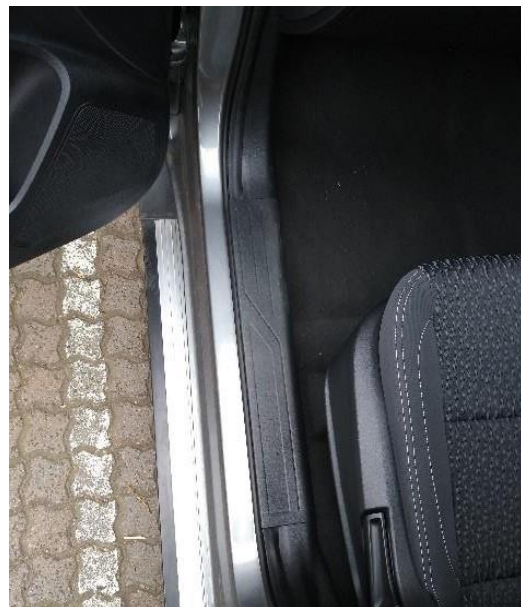

CANFSLDV

ISSUE 1

10/04/2019

Page No : 7/11

16

- Find the socket for brake lamp and demister and find the harness for LOCK & UNLOCK signal.

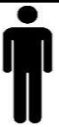
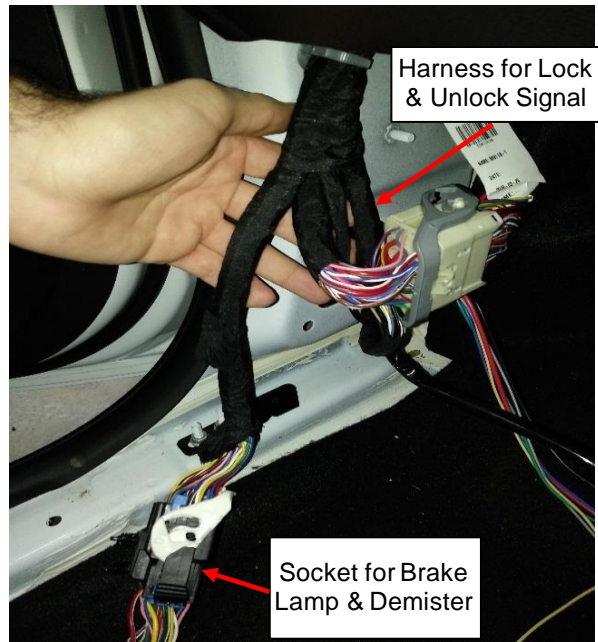

17

- Run the blue canopy brake lamp wire and join to the blue wire.
- Join the two power ends and insulate both joints with electrical tape.

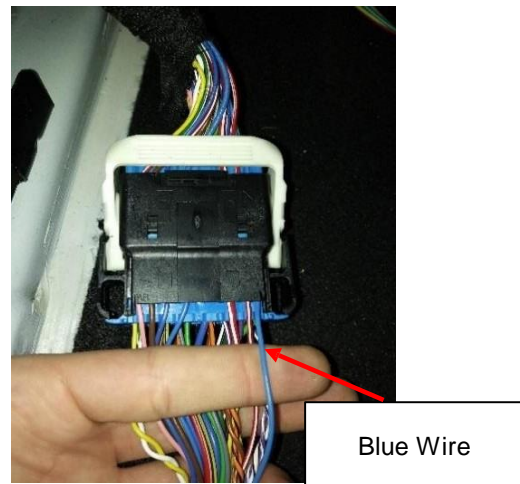

18

- Run the green canopy demister wire and join to the red/white wire.
- Join the two power ends and insulate both joints with electrical tape.

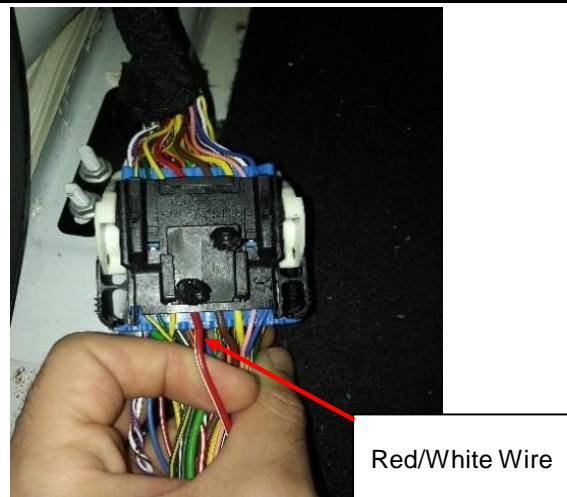

CANFSLDV

ISSUE 1

10/04/2019

Page No : 8/11

19

- Run the yellow canopy lock wire and join to the thick pale brown wire. (Use test light to identify the correct thick pale brown wire)
- Join the two power ends and insulate both joints with electrical tape.
- Run the grey canopy unlock wire and join to the thick grey wire.
- Join the two power ends and insulate both joints with electrical tape.

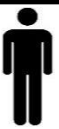
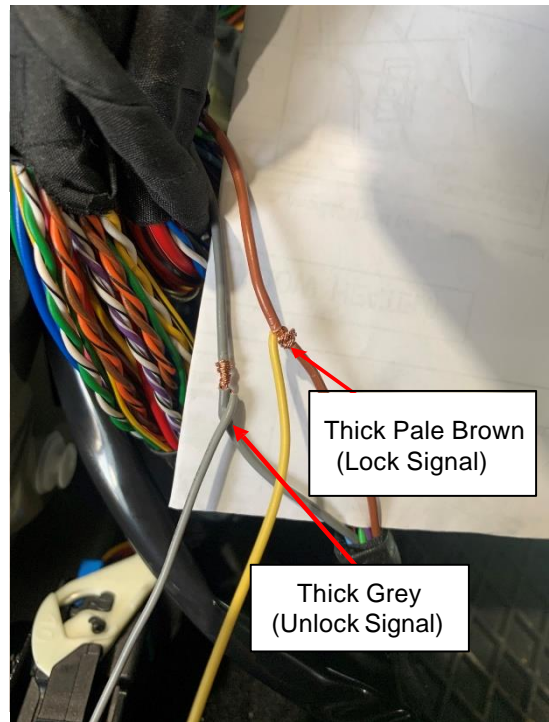

20

- Run the canopy earth (black with an eye terminal) to the attachment screw.

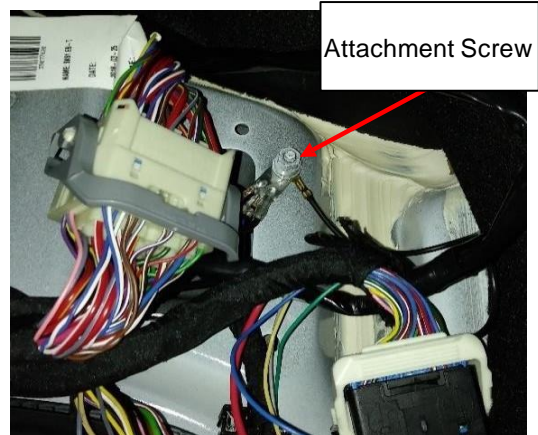

21

- Run power cable through the hole. (Do not forget to cover the power cable with PVC tube ~ 150cm) (As shown in the line drawing - Step 12)



CANFSLDV

ISSUE 1

10/04/2019

Page No : 9/11

22

- Run the canopy power (red with an eye terminal) to the battery positive terminal.



23

- Attached the fuse box with cable ties.
- Cover the power cable with PVC tube.

PVC Tube ~50cm

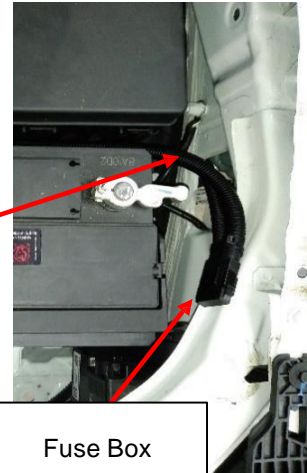

Fuse Box



24

- Beneath the vehicle run the harness from the hole to the front of the cabin. Keep it inside the chassis and away from the exhaust system, tie it with cable ties at regular intervals.
- The canopy harness relay is not a waterproof relay.
- We recommend to keep the relay behind the the kick panel.

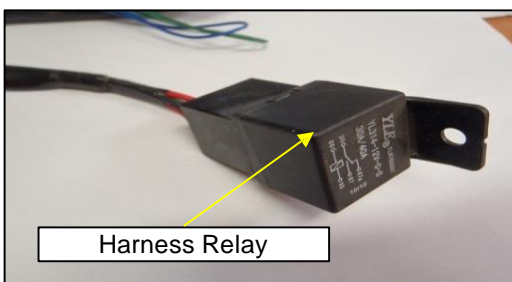

Harness Relay



CANFSLDV

ISSUE 1

10/04/2019

Page No : 10/11

25

- At the rear of the cabin connect it to the harness that comes from the front of the canopy, using the connectors provided.
- The canopy harness relay is not a waterproof relay.
- We recommend to keep the relay behind the the kick panel.
- Never place the relay out of the car .
- Check the function of the various wires ie, brake lamp, interior lamp, central locking and demister (use a test light on the power cable close to the rear door for this last item).
- If everything functions correctly the excess cable behind the cab can be bundled and secured with cable ties out of sight where it cannot work loose and drop down.
- Re-fit the covers around both foot wells and switch panel then clean and tidy the vehicle ready for inspection and delivery.



CANFSLDV

ISSUE 1

10/04/2019

Page No : 11/11