



FORD
PX RANGER DC 1Pce

Installation Instructions for
Primed
Hard Tonneau Cover

Place these instructions in vehicle's glove box after installation is complete.

IMPORTANT: Check that all listed components of this kit detailed in this document are present.

Item	Component Name	QTY
1	Primed lid	1
2	Fitting Instructions	1
3	Foam Tape Kit	1
1	Fitting Kit	1

Tools & Safety Equipment :

Electric drill, Phillips head drill bit, Torx bit T40, 5mm Allen key, Stanley knife, Masking tape, marking pen or pencil.

Hearing Protection, Eye Protection and Gloves as required

1. Remove primed lid from the box. Turn the lid upside down and place the lid on a stand
2. Mask up carpet ready for painting
3. Turn lid over and prep for painting



CAUTION: Lid has been primed using PPG Autothane primer
The primed lid requires appropriate sanding for two pack paint application

Recommendation:

Dry—P500 Sand Paper

Wet—P800 Sand Paper

1. Paint the lid.
2. Make sure that there is a 4cm border of paint underneath the whole lid.
3. After paint has cured, detail lid
4. After finishing detailing flip the part over. Fit foam tape kit to lid.

Ford PX Ranger DC 1Pce Primed Lid

Foam Tape Kit

Item	Description	Qty	Size
1	32mm x 3mm Tape	1	1.6mt
2	90mm x 5mm Tape	2	1.5mt
3	90mm x 5mm Tape	1	1.6mt

Installing Foam Tape Kit

1. Turn Lid upside down making sure to protect paint work.
2. Apply the 32mm x 3mm x 1.6mt Tape across front of lid.
3. Apply the 1st 90mm x 5mm x 1.8mt tape on side of lid, starting at front and making a 45 degree cut at rear
4. Apply the 2nd 90mm x 5mm x 1.8mt tape on side of lid, starting at front and making a 45 degree cut at rear
5. Apply the 90mm x 5mm x 1.6mt tape across the rear of the lid, Matching the 45 degree angle cuts in the rear corners as shown .

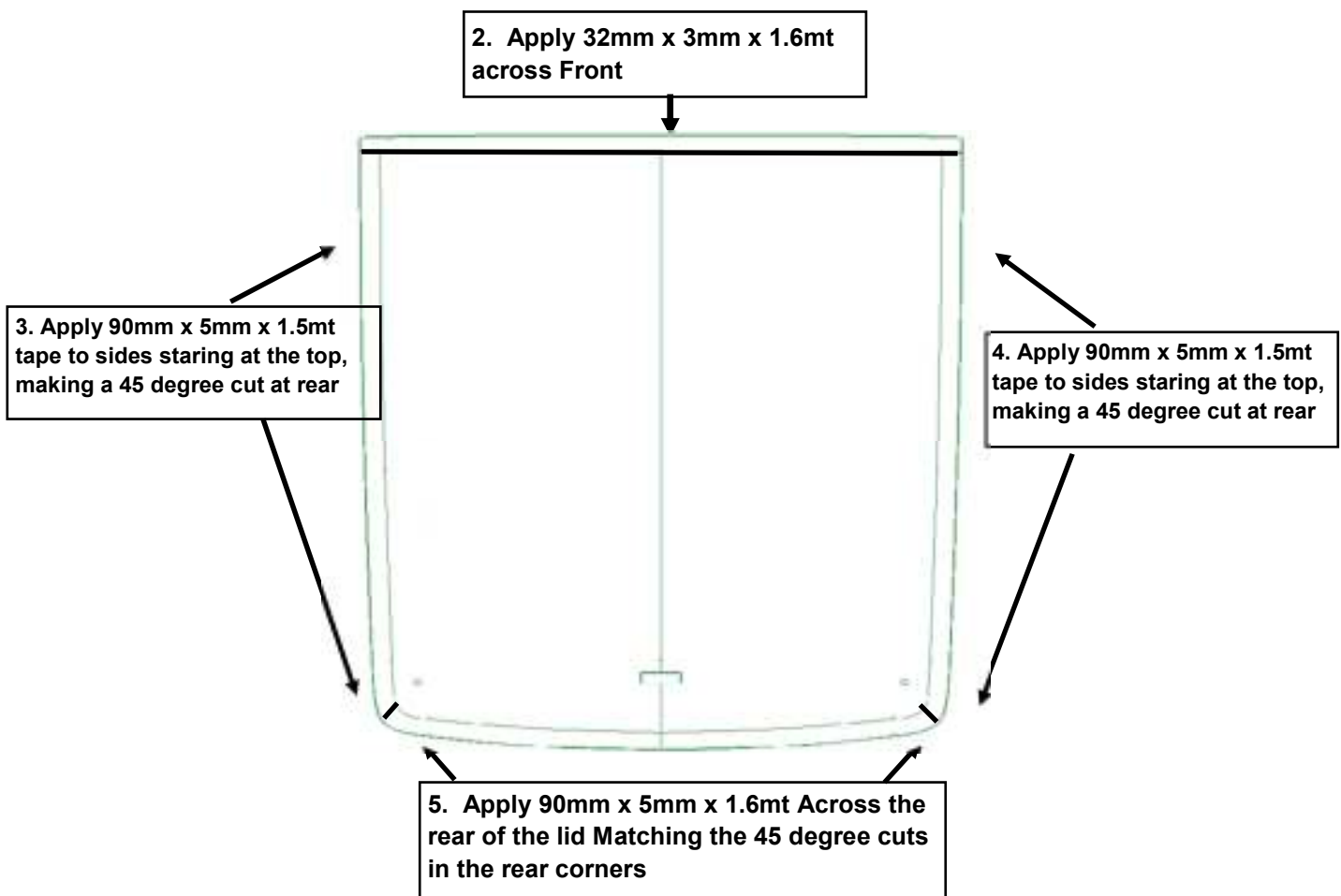

PX Ranger DC 1Pce

FITTING INSTRUCTIONS

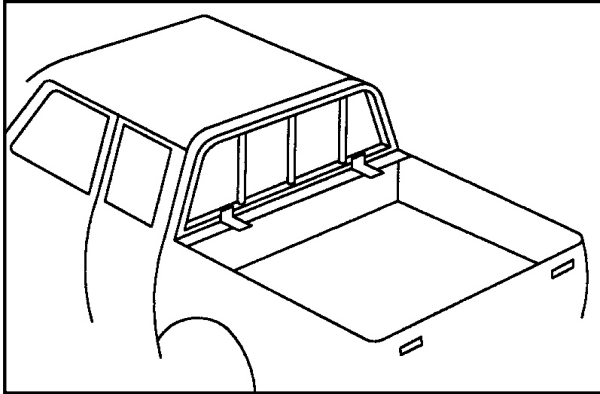

1. Remove the existing Header bar from the front of the tub using a T40 Torx screw bit, remove the 3 screws on each of the inside sections and 5 across the top of the header bar. Remove the Header bar.

2. Using a tape measure hook the tape measure over the front edge of the Ute body and measure back 970mm along the inside edge and mark the centre of the hole and 20mm down from the top edge of the body. Attach the two small gas strut brackets using

self-drilling screws. When tightening the 5 bolts on the FBA make sure that it is fitted as far to the rear as possible to maximize the gap between the rear of the cab and the hinge points.

NOTE: If the Ute has or is having a bedliner then this should be installed at this point.

3. The stainless steel Front Bar Assembly (FBA26) will fit over the top of the bedliner and install using the 4 - M6 x 20mm bolts supplied in fitting the kit. Some brands of bedliner might need to be trimmed. Apply silicone along the full length under the FBA Bar, complete the FBA Bar Installation by using 5 of the Tex screws supplied.
4. When tightening the 4bolts on the FBA make sure that it is fitted as far to the rear as possible to maximize the gap between the rear of the cab and the hinge points.
5. Using the Alcohol wipe supplied Wipe down the FBA Bar. Peel the protective backing from the sections of tape on either side of the FBA and adhere to the ute body
6. **NOTE OVER RAIL BEDLINERS:** The gas strut brackets and lock brackets should be screwed through the Bedliner, ensuring that the thread installs into the metal of the body. It is advised that you remove Bedliner after drilling in order to clean away any filings, which may lead to rust at a later date.
7. Attach the small shaft end of the gas struts onto the gas strut brackets, by 'clicking' them in place.
8. With the lid upside down, unscrew the 3 Phillips head screws [each side] and fit the matching gas strut brackets onto the lid.
9. With one person on each side, carefully lift the Lid vertical and insert the hinge tongues into the hinge slots on the front bar assembly. Carefully lower the lid, ensuring that the tongues are fully inserted into the hinge slots.

Note: The gas struts may be removed at any time to remove the Lid by inserting a small screwdriver under the metal spring clip on the gas strut end and gently easing it out. You can then pop the strut off the ball. Never completely remove the spring from the gas strut end, and never force the strut off the ball.

10. Attach the cylinder end of the gas struts onto the brackets on the Ute Lid. Adjust the rear lock brackets up or down until light pressure is required to lock the lid.
11. **Note:** The gas struts may be removed at any time to remove the Lid by inserting a small screwdriver under the metal spring clip on the gas strut end and gently easing it out. You can then pop the strut off the ball. Never completely remove the spring from the gas strut end, and never force the strut off the ball.
12. Close the Lid and check to see if it fits snugly and evenly around both sides and the back. Make sure it sits down snugly over the tailgate. If it does not, then adjust as follows:
 - A:** Open the Lid and disconnect the gas struts from the brackets on the Lid.
 - B:** Loosen the 4 Allen key bolts on each of the two hinge tongues on the Lid.
 - C:** One person needs to lie on their back in the utility while the second person closes the Lid and adjusts the fit by settling the Lid into the ideal position. The person in the Ute then re-tighten the Allen head bolts before opening the Lid.
 - D:** Open the Lid and reattach the gas struts.
13. To fit lock brackets, open tailgate and close the Lid. Make a mark where the lock cam (arm) lines up with the sides of the Ute body. Open lid and install lock bracket with the self-drilling screws supplied (ensuring that the thread installs into the metal of the Ute rail), allowing for adjustment up and down.
14. Close the Lid and check the locking action each side. Raise or lower the lock brackets until only **slight** pressure is needed to lock the Lid.
Do not over-tighten as this may cause damage to the locks.

Your utility should now look fantastic with its new lid fitted. Remember, when removing and re-fitting your Ute lid ensure that the hinges are fully engaged to avoid damaging or bending them.

MAINTENANCE: Painted Lids will need to be polished and kept clean just as you would the other painted areas of you vehicle. Regularly check that all brackets and screws are tight.

WARNING – Don't allow people or animals beneath the Lid. Don't place excessive weight on Lid. Always lock the Lid when driving or reversing.