



TOYOTA
HI-LUX DC "A" DECK 3Pce

**Installation Instructions for
Primed
Hard Tonneau Cover**

Place these instructions in vehicle's glove box after installation is complete.

IMPORTANT: Check that all listed components of this kit detailed in this document are present.

Item	Component Name	QTY
1	Primed lid	1
2	Fitting Instructions	1
3	Foam Tape Kit	1
1	Fitting Kit	1

Tools & Safety Equipment :

Electric drill, Phillips head drill bit, Torx bit T40, 5mm Allen key, Stanley knife, Masking tape, marking pen or pencil.

Hearing Protection, Eye Protection and Gloves as required

1. Remove primed lid from the box. Turn the lid upside down and place the lid on a stand
2. Mask up carpet ready for painting
3. Turn lid over and prep for painting



CAUTION: Lid has been primed using PPG Autothane primer
The primed lid requires appropriate sanding for two pack paint application

Recommendation:
Dry—P500 Sand Paper
Wet—P800 Sand Paper

1. Paint the lid.
2. Make sure that there is a 4cm border of paint underneath the whole lid.
3. After paint has cured, detail lid
4. After finishing detailing flip the part over. Fit foam tape kit to lid.

TOYOTA HI-LUX DC "A" DECK 3Pce Primed Lid

Foam Tape Kit

Item	Description	Qty	Size
1	32mm x 3mm Tape	1	1.4mt
2	90mm x 5mm Tape	2	90mm
3	90mm x 5mm Tape	1	1.7mt
4	Pre-cut Rear Corners	2	
5	32mm x 3mm Tape	2	90mm

Installing Foam Tape Kit

1. Turn Lid upside down making sure to protect paint work.
2. Apply the 32mm x 3mm x 1.4mt Tape across front of lid.
3. Apply the 32mm x 3mm x 90mm Tape to the cut out returns on both sides
4. Apply the 90mm x 5mm x 90mm tape on side of lid, starting at the return. On both sides
5. Apply the Pre Cut Corners at the rear of lid.
6. Apply the 90mm x 5mm x 1.6mt tape across the rear of the lid.

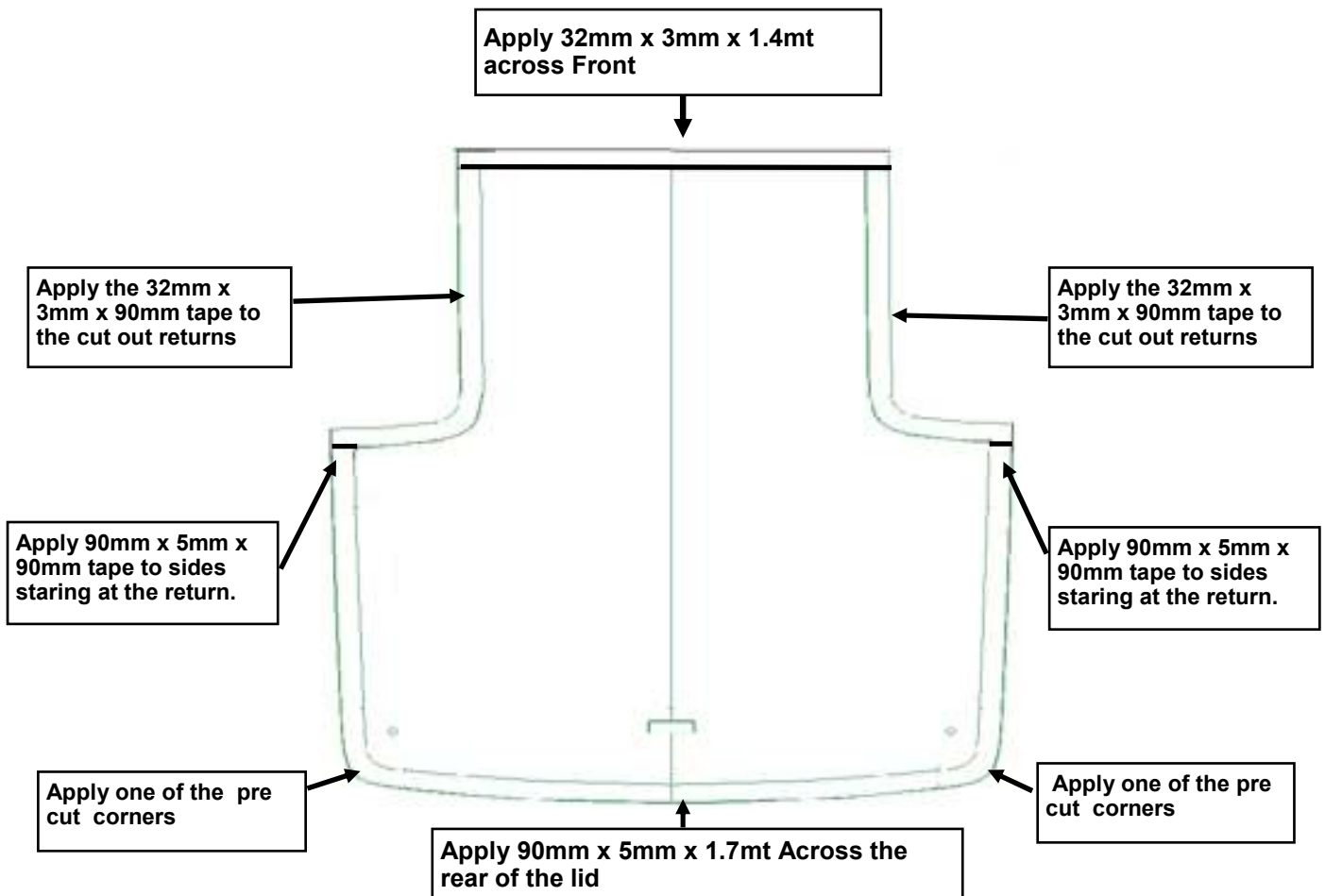

TOYOTA HI-LUX DC "A" DECK 3Pce **FITTING INSTRUCTIONS**



NOTE: For vehicles without a Ute liner Follow 1. Then Skip to 3.

Never Fit Front Bar Assembly of tonneau over a ute liner

CAUTION:

Over tightening fasteners attached to the hard tonneau cover may damage the threaded inserts. Please use recommended tightening torques where specified.

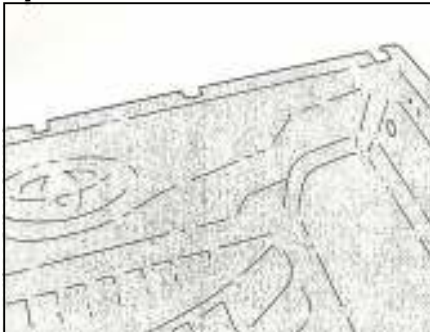

Remove Ute Liner

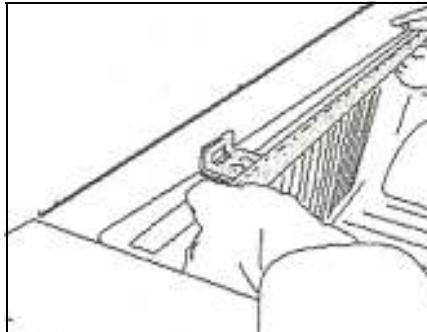

Fig. 1

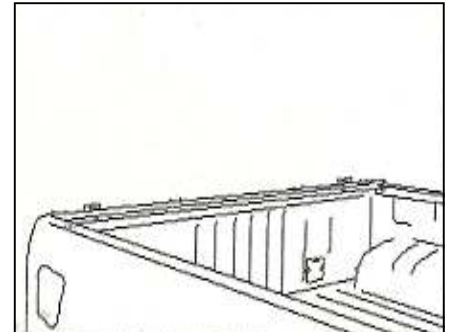

Fig. 1A

1. With Ute liner removed, fit front bar assembly (FBA) first.

Align bar along front of tray. Remove the tape from the rubber seal and attach the FBA using 9 self drilling screws (supplied) through holes pre-drilled in bar. Apply clear or black silicone to any gaps between the FBA and the vehicle to prevent water entry.

REFER to FIG. 1 and Fig. 1A

Remove backing from the foam tail and stick down the tail to the top of the metal rail.

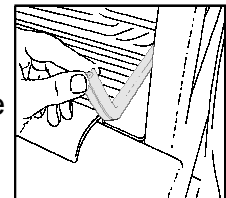

For all Ute liner cut-outs, mark a line with white or yellow marker on liner

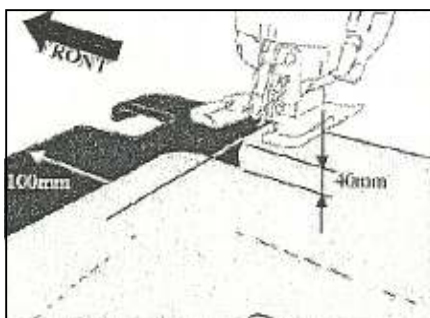

Fig. 2A: Initial cut of ute liner front section (RHS Shown)

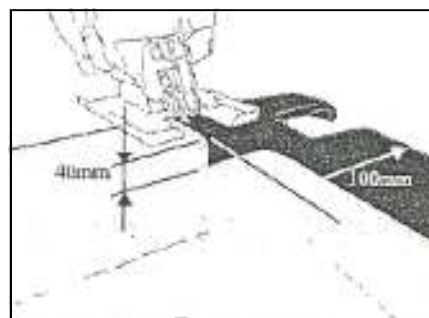

Fig. 2B: Initial cut of ute liner front section (LHS Shown)

2A. Measuring from front edge of ute liner rail lip, mark a line (see Fig. 2A)

2B. Repeat this for LHS (see Fig. 2B)

Keeping the same depth of 40mm, Continue the line as shown along inside of front face of the liner from the RHS front corner to the LHS front corner.

Using a Jig Saw, cut the liner along the marked line and remove blackened section as shown in **2A & 2B.**

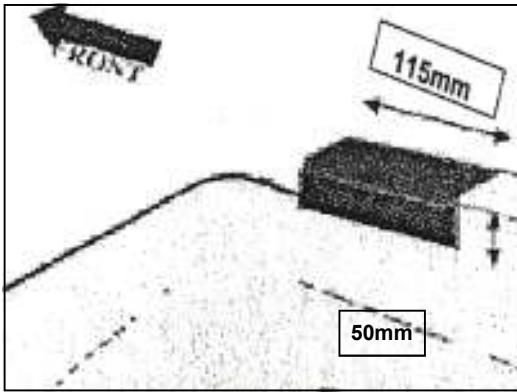

Fig. 2C: Secondary Cut (RHS shown)

2C. Measuring from the edge of the first cut, Mark a line 115mm Backwards from cut edge and 50mm down the inside face of the liner (**see Fig.2C**). Cut along line as marked

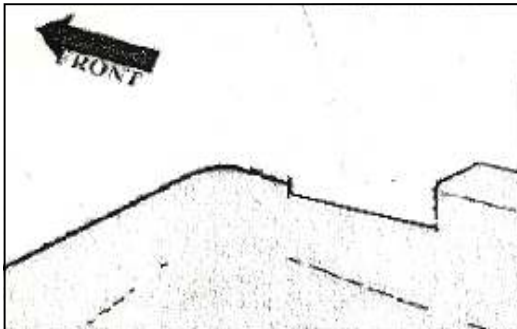

Fig. 2D: Shape of ute liner after secondary cut

2D. Fig. 2D Shows shape of the correctly cut ute liner. Repeat this step for LHS.

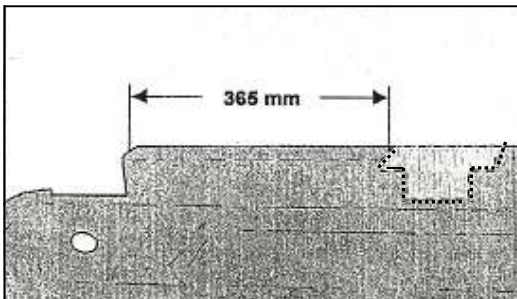

Fig. 2E. Final cut of Ute liner (RHS shown)

2E. Measured from the edge of the secondary cut, Mark a line 365mm backwards from the cut edge (see Fig. 2E).

2F. Mark a line as per Fig. 2F

Using a Jig Saw cut the liner along the marked line and remove "T" section as shown.

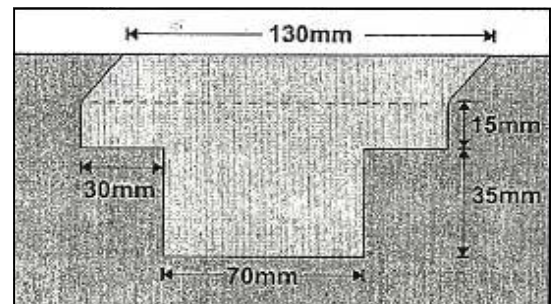

Fig. 2F: Measurement for cutting "T" Section

Repeat this step for LHS

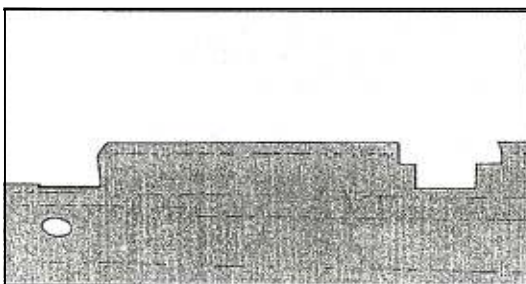

Fig. 2G: Final shape of cut Ute liner after cutting

2G. Fig. 2G Shows the final shape of the correctly cut ute liner.

Reinstall the Ute Liner to vehicle.

3. Re-Install trimmed Ute Liner so it fits under the Front Bar Assembly (FBA) of the Tonneau

NEVER FIT FBA OVER UTELINER

NOTE: The Gas Strut Brackets are fitted through the Ute Liner.

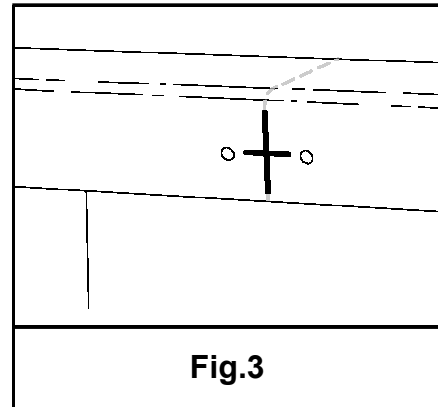
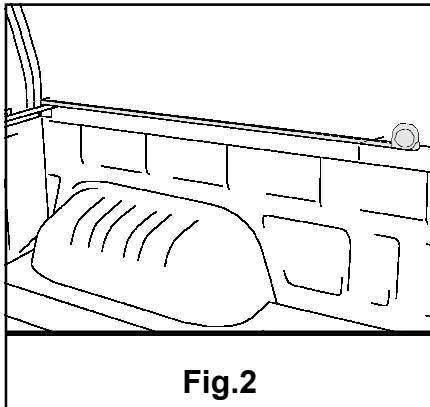

- 3A.** Hook tape measure over front edge of tub, measure along top edge of tray **1040mm** then down **30mm** and mark the ball position for the gas strut bracket. Position the gas strut bracket accordingly, mark both mounting holes and center punch.

Refer to Fig. 2 and Fig. 3

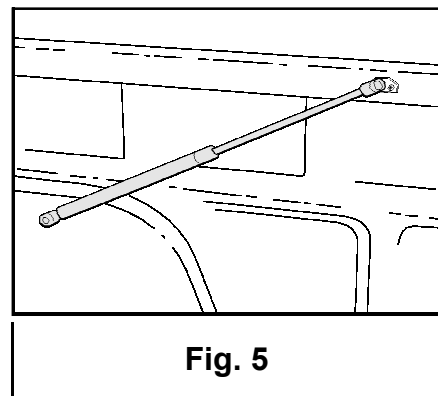
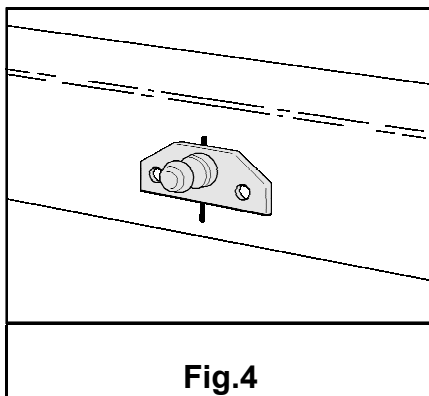

4. Using a drill-stop set to 5 mm, drill two pilot holes using 2 mm diameter drill bit and attach small gas strut bracket using self-drilling screws. Repeat process on other side of tray.

Refer to Fig. 3 and Fig. 4

Attach small shaft end of gas strut onto gas strut brackets, by clicking them in place.

Refer to Fig. 4 and Fig. 5

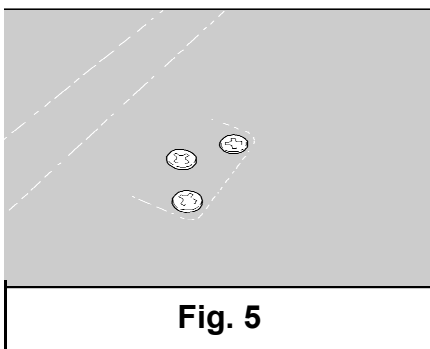

- 5.** Ensuring the lid is adequately supported to prevent damage or scratches, unscrew the 6 Phillips head screws from the underside of the lid (3 per side) and use them to fit the upper gas strut mounting brackets to the lid.

Refer to Fig. 5A



Important:
DO NOT over tighten screws.
Recommended tightening torque is 1-3 Nm

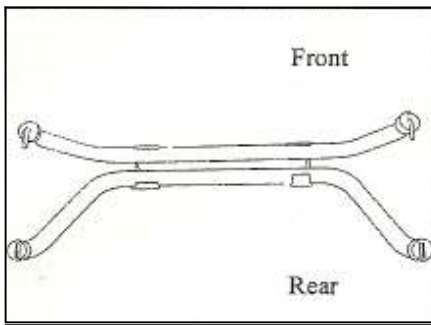

Fig. 5

5. Turn the Sportsbar upside down.
Refer to Fig. 5

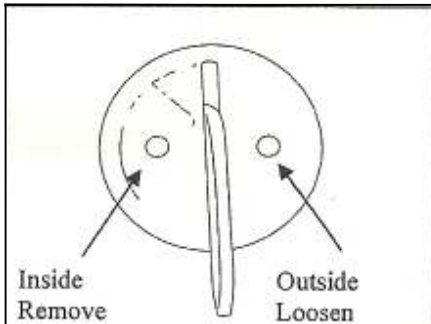

Fig. 5A

- 5A. For front legs of the sport bar, remove inside bolt and loosen outside bolt.

Refer to Fig. 5A

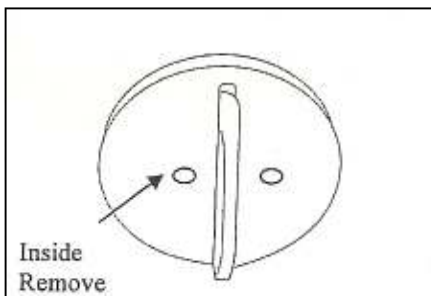



Fig. 5B

- 5B. For rear legs of the sport bar, remove inside bolt
Refer to Fig. 5A

 **Step 5C must be followed to ensure a water tight seal between the moulded feet cups and the moulded inserts**

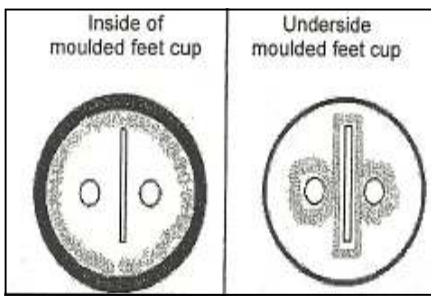

Fig. 5C



Remove all Moulded Foot Cups from the Sportsbar trim the underside flat.

- 5C. Apply a small bead of silicone on the inside of the moulded feet cups around internal corner. On the underside of the moulded feet cups, apply a small bead of silicone around slot and holes.

Refer to Fig. 5C

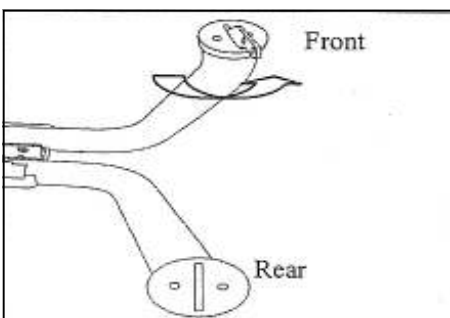

Fig. 5D

- 5D. Fit the moulded feet cups, For the front legs turn the feet to the outside direction

Refer to Fig. 5D

Loosen eight bolts of the black Sportsbar channel.

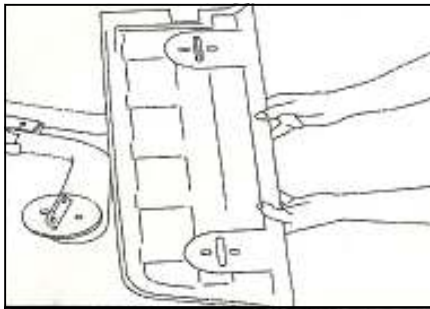

Fig. 5E



IMPORTANT:
Cover the edges of the moulded inserts with protective masking tape to prevent damage during fitment.
Remove tape after fitment.

5E. Install the moulded insert by placing it at the front feet first.

Refer to Fig. 5E

Refer to Fig. 5D for correct orientation of moulded insert



Fig. 5F

5F. Lift up the moulded insert and place it onto the rear foot. Straighten front mounting brackets of Sportsbar.

Refer to Fig. 5F



Be careful not to scratch the painted moulded insert on the Sportsbar

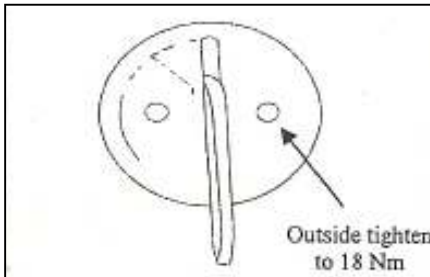

Fig. 5G

5G. Tighten Sportsbar mounting outside bolts to 18Nm repeat process on other side of Sportsbar..

Refer to Fig. 5G

5H. Support brackets are supplied for left and right side (marked "L" for LHS infill support bracket and "R" for RHS infill support bracket).

Refer to Fig. 5H & 5J for correct orientation for this bracket.

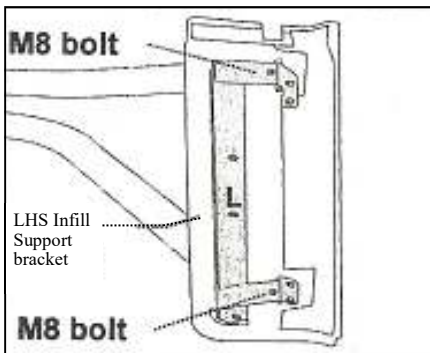

Fig. 5H

5J. For installation of support bracket on moulded insert, place steel support bracket on the underside of moulded insert. Install by using 2 x 45mm M8 Bolts and M8 Washers supplied In Support bar box, fastening one at the front and one at the rear of the foot.

DO NOT FULLY TIGHTEN.

Repeat process on other side of Sportsbar.

Refer to Fig. 5H

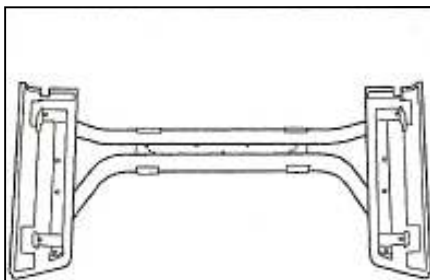

Fig. 5J

To install the adjustment bolts on the infill support brackets (6 x 25mm M6 Bolts with nuts supplied in support bar box) Fasten nuts on bolts and screw the bolts into the threaded holes of the infill supports bracket until the bolts touch the metal plates fixed to the underside of the moulded insert. Repeat process on the other side of Sportsbar.

Refer to Fig. 5J

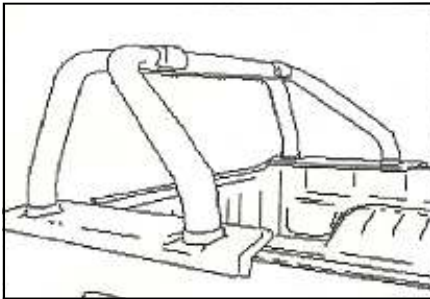

Fig. 5K

5K. Using 2 People, position Sportsbar assembly as shown in **Fig. 5K**

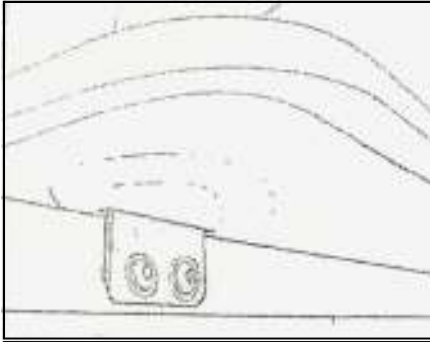

Fig. 5L

5L. Install the Sportsbar using bolts supplied with the Sportsbar.
DO NOT FULLY TIGHTEN
Refer to Fig. 5L

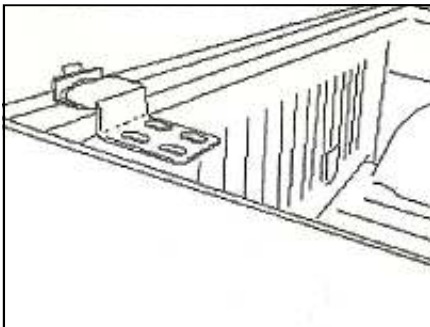

Fig. 6

6. Remove the hinge tongues from the lid (four Allen key bolts on each side). Place hinge tongues into hinge slot already fitted to the vehicle.

Refer to Fig. 6

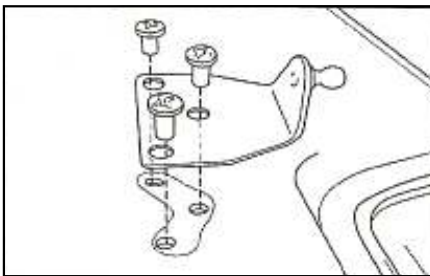

Fig. 7

7. With the lid upside down and taking care to prevent damage or scratches to the painted surface, Check that the Lid strut Brackets are tightened.

Refer to Fig. 7



IMPORTANT:
Do not over tighten screws.
Recommended tightening torque is 1 to 3 Nm

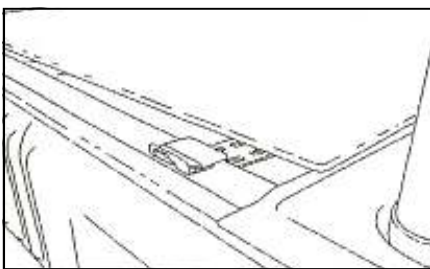

Fig. 8

8. Place hard tonneau cover into position ensuring uniform gap between cover and infill panels, as well as between cover and vehicle body.

Refer to Fig. 8

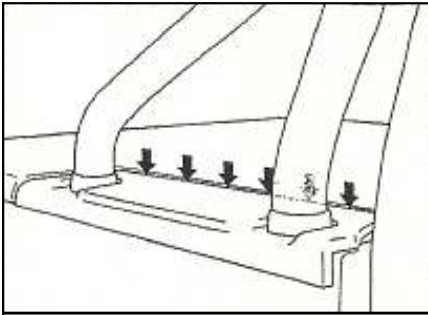

Fig. 10B

10B. With the lid closed, adjust six adjustment bolts (25mm M6 Three on each side) from inside the tub until no light can be seen through the join (as indicated by arrows) between the lid and the inserts. Using M6 nuts, lock bolts into place.

Refer to Fig. 10B

11. Close lid and check it fits snugly and evenly around all sides. Make sure it also fits down snugly over the tailgate. If it does not, then adjust as follows:

- a. Open lid, disconnect struts from lid.
- b. Loosen four Allen key bolts on each side of the two hinge tongues on the lid.
- c. One person needs to lie on their back in the utility while second person closes lid and adjusts the fit by setting lid into ideal position. The person in the Ute then re-tightens the Allen head bolts before opening lid.
- d. Open lid and reattach gas struts.

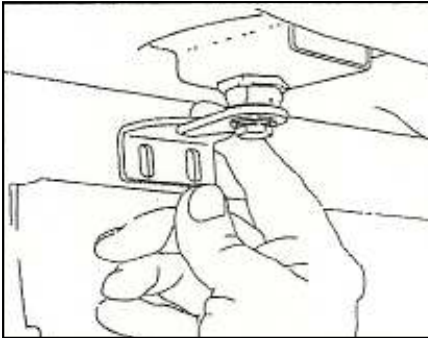

Fig. 11

12. To fit lock brackets, open tailgate and close lid. Make a mark where the lock cam (arm) lines up with the sides of the Ute body. Open lid to install lock bracket. Position lock bracket and using a 2mm Diameter drill bit set to 5mm drill stop to drill pilot hole in each vertical slot of the bracket. Fasten bracket with self-drilling screws (supplied) ensuring thread installs into metal of Ute rail allowing for up and down adjustment.

Refer to Fig.11

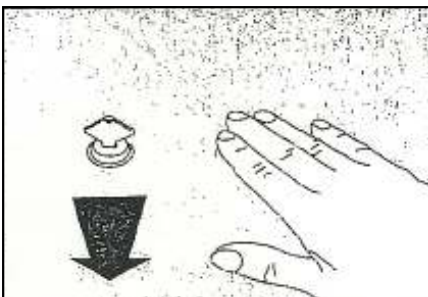

Fig. 12

13. Close the lid and try the locks. You may need to adjust the lock brackets on the Ute tub up or down. When correctly adjusted, you should need to apply slight pressure to the lid in order to operate the locks.

Refer to Fig. 12 and 12A

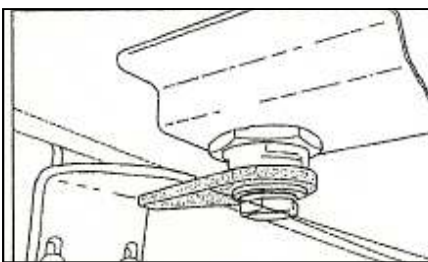

Fig. 12A



Important:

To remove the lid from the vehicle, detach the gas struts from the lid. This is done by inserting a small screwdriver under the metal spring clip on the strut and easing it out sufficiently to allow the strut to be popped off the ball.

Never completely remove the metal spring clip from the gas strut end, and never force the strut off the ball.

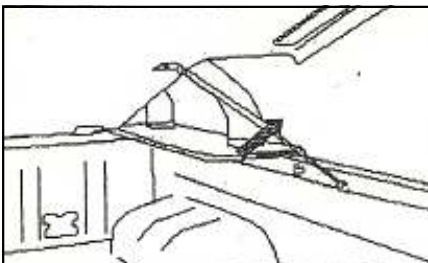

Fig. 13

Your utility should now look fantastic with its new lid fitted. Remember, when removing and re-fitting your Ute lid ensure that the hinges are fully engaged to avoid damaging or bending them.

MAINTENANCE: Painted Lids will need to be polished and kept clean just as you would the other painted areas of your vehicle. Regularly check that all brackets and screws are tight.

WARNING – Don't allow people or animals beneath the Lid. Don't place excessive weight on Lid. Always lock the Lid when driving or reversing.