



# FLEXIGLASS FITTING MANUAL - SECTION 3.3G

## FLEXIGLASS FORD RANGER(PX) DC 2011 SBA TRAY FIT - ISSA8

**Note:** Familiarise yourself with the instructions before you start to ensure you are clear on all aspects of the fit

### SAFETY EQUIPMENT

- Hearing protection as required
- Eye protection as required

### TOOLS REQUIRED

- Pneumatic / electric drill
- Pneumatic / electric hacksaw
- Drill bits: 21/64", 1/4" & 3/16"
- Sockets: 10, 13 & 18
- Würth Cable strippers
- Pneumatic driver
- Rivet gun with 5mm tip
- Loctite 243
- Toledo cable strippers

**NOTE:** If the vehicle is 2WD Hi-Rider or 4WD, 1 x PAN520 LHS & 1 x PAN530 RHS are required to replace 1 x PAN440 LHS & 1 x PAN450 RHS which are in TRSTDFITKIT.

### TRFITR11D Tray Fit Ranger 11 DC - Kit BOM

Type	No.	Description	Quantity per	Unit of Measure Code
Item	BLK200C	Block For Cross Bars 40MM Coat	6	EACH
Item	BLTHHZP1290	Bolt & Nut Hex ZP 12X90mm	6	EACH
Item	NUT12C	Nut Channel M12	6	EACH
Item	NUT6N	Nut Nyloc M6	32	EACH
Item	NUT8N	Nut Nyloc M8	12	EACH
Item	PLT390C	Fish Plate forTrayBearers Coat	6	EACH
Item	SCRHSS620	Screw Set Hex Head S/S 6x20mm	32	EACH
Item	SCRHSS825	Screw Set Hex Head S/S 8x25mm	12	EACH
Item	SPACER30	Mounting Spacer 50 X 50 X 3	2	EACH
Item	SPACER40	Mounting Cross Bar Spacer	4	EACH
Item	SPACER50	Mounting Block Spacer 10MM	4	EACH
Item	SPACER60	Plastic Packer Spacer 4.5	2	EACH
Item	TIE100	Tie Cable BLK 4.8x300mm	6	EACH
Item	WSH220	Washer 5/16 X 3/4 Flat	12	EACH
Item	WSH10	Washer BRT Z/P 1/2x1-7/8x14G	6	EACH
Item	WSH300	Washer Spring Z/P 12x2.5x2.5mm	6	EACH
Item	BAR310FC	Bar Universal Cross Mount Coat	3	EACH
Item	WSH180	Washer Brt Z/P 1/4x5/8x18G	10	EACH
Item	WSH240	Washer Brt Z/P 1/2x1-1/8x16G	6	EACH
Item	SCRPHSS416	Screw Phil/Head SS M4x16	4	EACH
Item	NUTSSM4	Nut Stainless Steel 4MM	4	EACH
Item	BKT750	Bracket Fuel Filler PX/BT50	1	EACH
Item	TRSTDFITKIT	Tray STD Fitting Kit	1	KIT
Item	NUT10N	Nut Nylon Insert Lock ZP 10MM	8	EACH
Item	BLTHHZP640	Bolt & Nut Hex ZP 6X40mm	4	EACH

## FIT INSTRUCTIONS

- 1 Refer to **ILL 1** showing dual cab mounting positions. Locate these positions on the vehicle.  
**Note:** All mount points on the vehicle must be used when fitting a Flexiglass Tray.
- 2 Slacken the screw clamp securing the filler hose to the neck and rotate the neck anti-clockwise until the metal breather tube is at the top of the neck, re-tighten the screw clamp.
- 3 Refer to mount diagrams on **Page 3** which illustrates standard part usage for mounts on DC Ranger PX and Flexiglass Tray.
- 4 Fit the mounts in place on the chassis, using the parts and applying lock tight to thread as shown in the diagrams on **Page 3**.

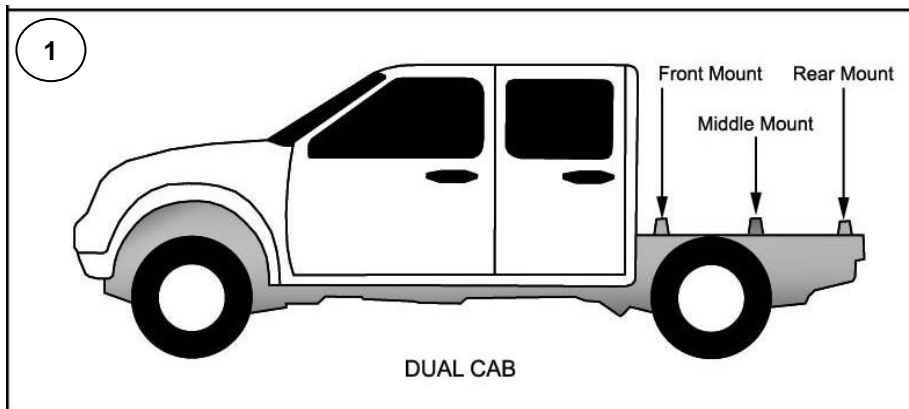

- 5 With all parts in place and the bolts still loose check the front and rear mounts are central over the chassis by measuring from the inside of one mount cleat to the inside of the opposite chassis rail. Repeat this for the other mount cleat and rail sliding the mounting cross bar "to and fro" until the measurements are equal. See **ILL 2**.
- 6 Tighten the four bolts securing the mount bars to the chassis mounts front and rear.
- 7 Place a length of **ALUM10** between the vertical faces on one side of the front and rear mounting cross bar cleats and clamp it to them. See **ILL 3**.
- 8 Slide the middle cross bar across until the cleats are against the same face of the angle as the front and rear cleats. **Note:** This ensures that all three bars are now central and in line with each other.
- 9 Tighten the two bolts securing the middle mounting cross bar.

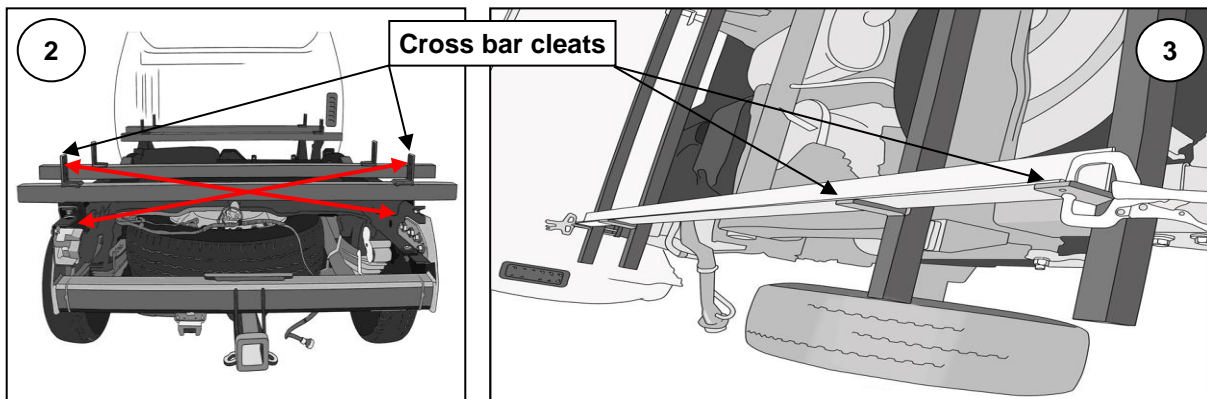

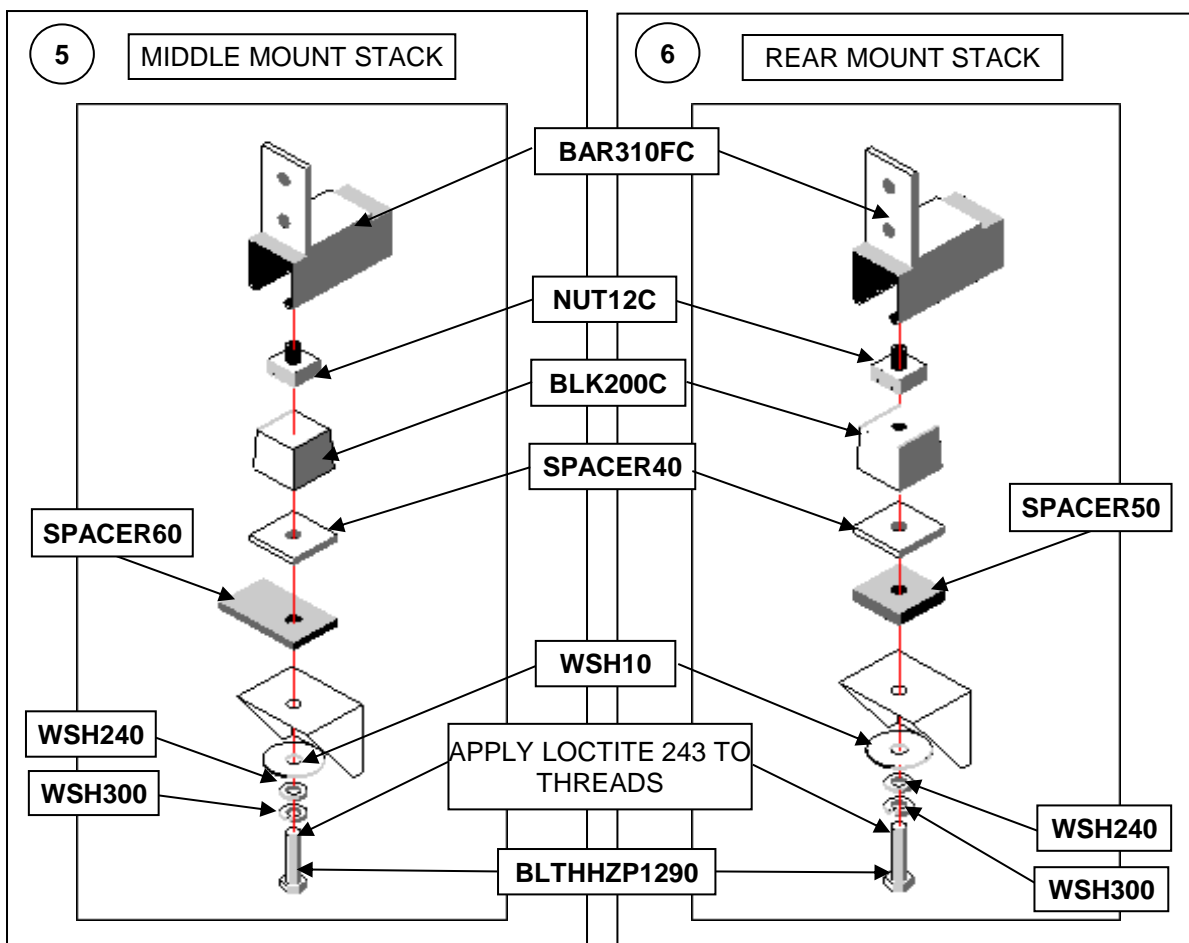
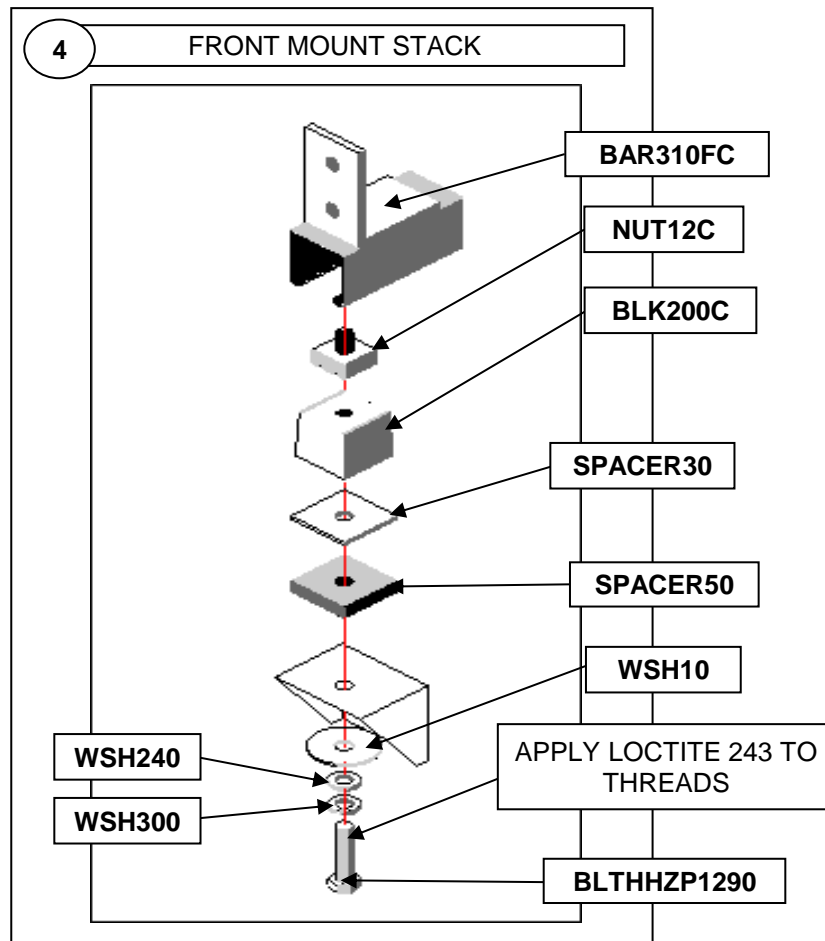

- 11 Remove the brace/bearer bolts from both sides and place the tray on the mounting cross bars, locating the the bearer flush with the front of the cross bar cleat, ensure the rear overhang does not exceed 700mm.
- 12 Once the tray is lined up drill 21/64" holes into the bearers using the mounting cross bar as a guide. See ILL 7.

**Note:** It will not be possible to fit **PLT390C** fishplates to the front crossbar position.

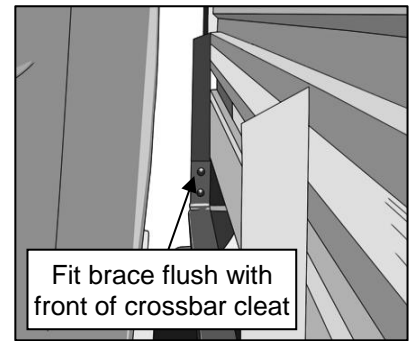

- 13 Secure tray to the bearers as shown in the diagrams adjoining.
- 14 The stays are mounted to the mudguards, using the pre-drilled holes, with 1 each **SCRHHSS620**, **WSH180** & **NUT6N**.

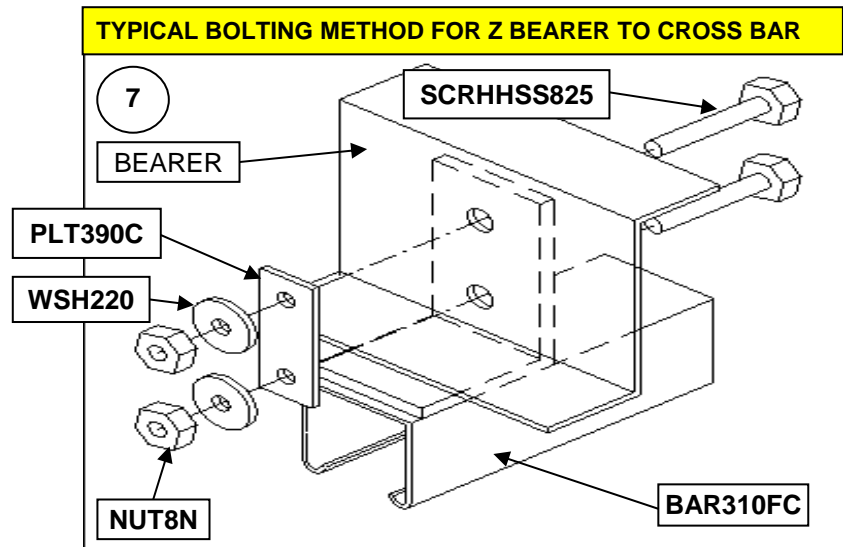

- 15 Mark and drill a 1/4" hole on the centres shown in ILL 8 on one **PAN440** & one **PAN450**.

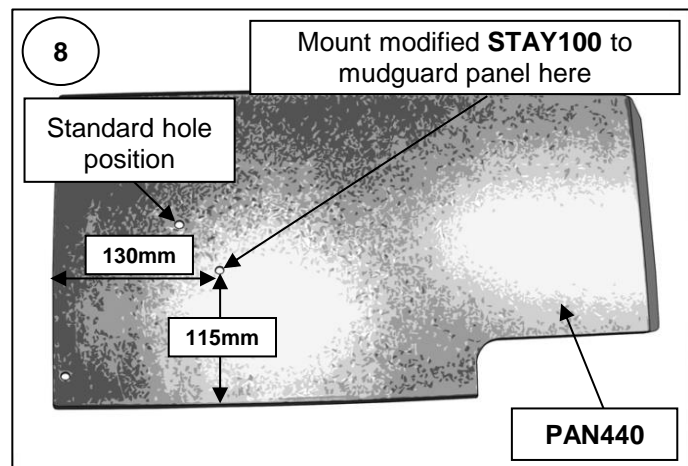

- 16 On the two **STAY200** front stays drill an extra hole 10mm from the edge of the top flange, as shown in **ILL 9**.
- 17 On one **STAY200**, position the **BKT750** as shown in **ILL 9**. The bottom corner is positioned at the intersection of the three creases on the stay and the edges are kept flush with each other. Drill 1/4" holes through the stay, matching the **BKT750**.

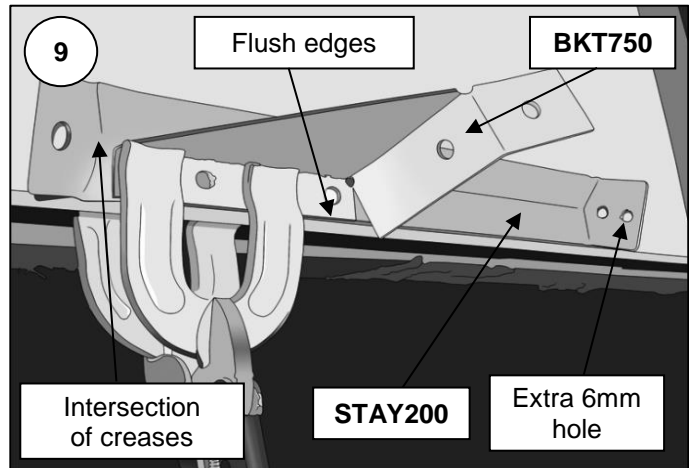

- 18 Drill a 1/4" hole through the bottom flange of the front plank on the centre indicated in **ILL 10**. Use the guide line groove to help position the drill bit and drill holes on both sides of the tray.

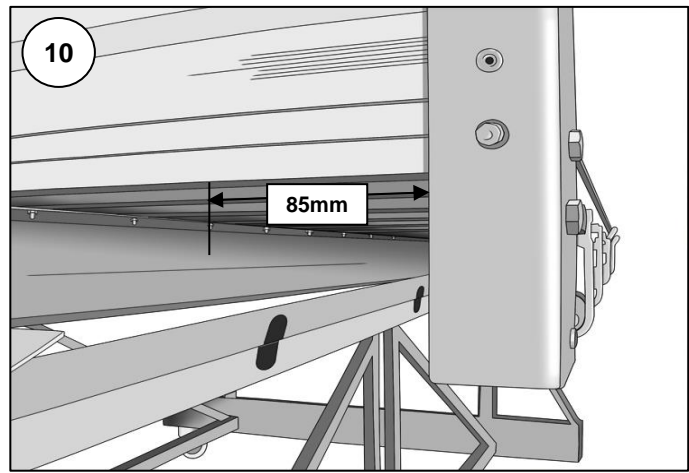

**MOUNTING OF TWO PART MUDGUARDS**

11

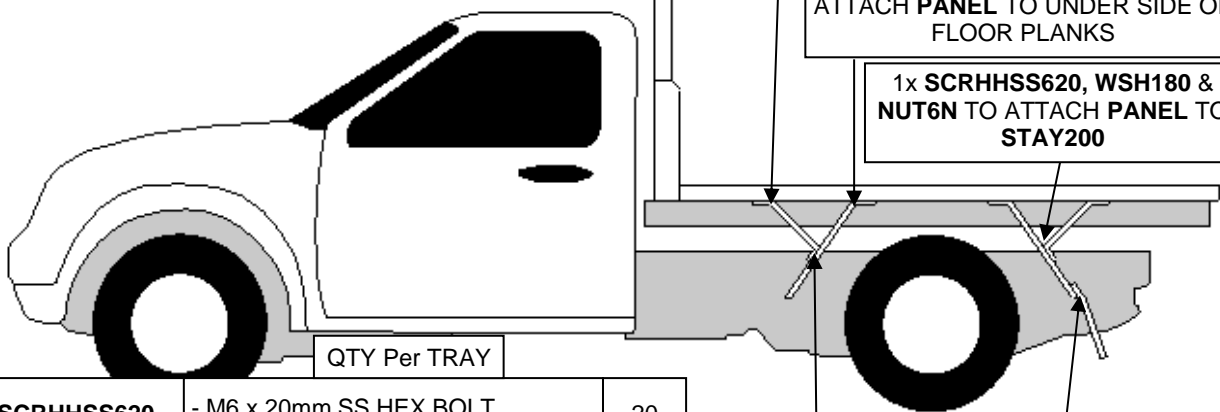

		QTY Per TRAY
<b>SCRHHSS620</b>	- M6 x 20mm SS HEX BOLT	20
<b>NUT6N</b>	- M6 NYLOC NUT	20
<b>WSH180</b>	- 6mm FLAT WASHER	4
<b>PAN440</b>	- L/H 275mm MUDGUARD PANEL	1
<b>PAN450</b>	- R/H 275mm MUDGUARD PANEL	1
<b>PAN520</b>	- Left H/S Rear Mudguard Panel	1
<b>PAN530</b>	- Right H/S Rear Mudguard Panel	1
<b>STAY200</b>	- MUDGUARD STAY	4
<b>MFLP310</b>	- MUDFLAP STANDARD	2
<b>STRAP200</b>	- MUDFLAP STRAP	2

**STAY IS BOLTED THROUGH PRE-PUNCHED HOLES IN PANELS.**

- 19 Mount the mudguards to the underside of the tray deck by lining up the pre-punched holes in the mudguard with one of the ribs running along the underside of the tray. Attach with 2 of **SCRHHSS620** & **NUT6N**.

**Note:** The holes, pre-punched in the plank flange, position the mudguards at their widest position without reference to the vehicle track width. Legally the guard must cover both sidewalls of the tyres which may require the guard panels to be positioned off the plank holes.

Make sure the spacing between the mudguard and wheel is sufficient for both aesthetic and functional purposes. See **ILL 11** above.

- 20 Attach the other end of the stay to the underside of the tray using same method but with only one fixing.

**Note:**

The front stays should be hooked over the top of the front plank flange and the extra hole will line up so that the edge of the stay flange remains hidden.

- 21 Rest the filler neck bracket on the **BKT750**, align the holes and attach the filler neck with two of **SCRHHSS620** & **NUT6N**. See **ILL 12**.
- 22 Drill a 7mm (9/32") hole through the bottom of the headboard angle adjacent to the fuel filler and push the plastic button of the fuel cap retainer into it.

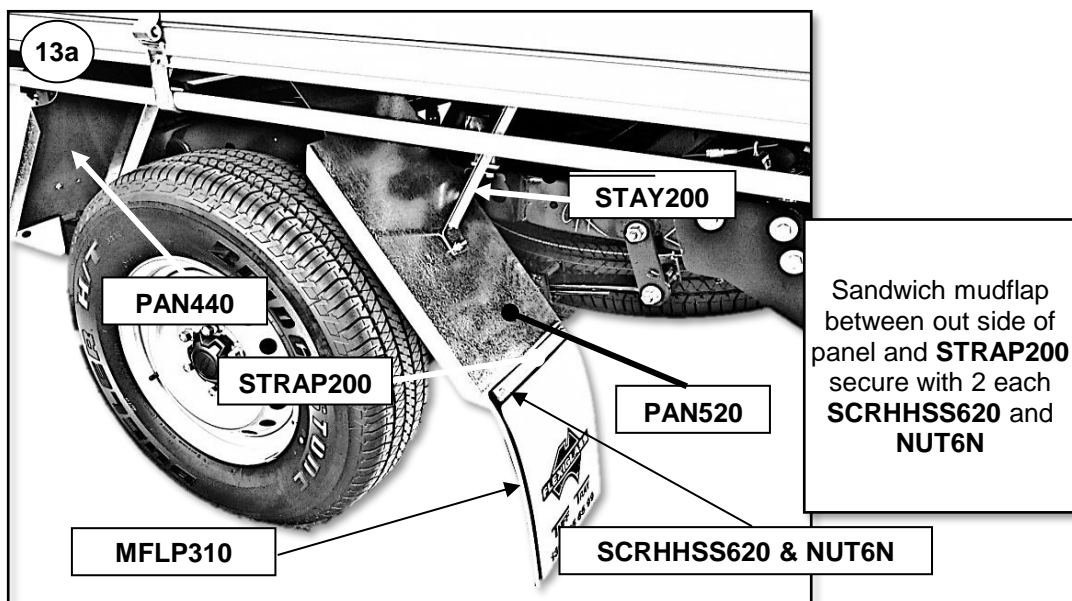
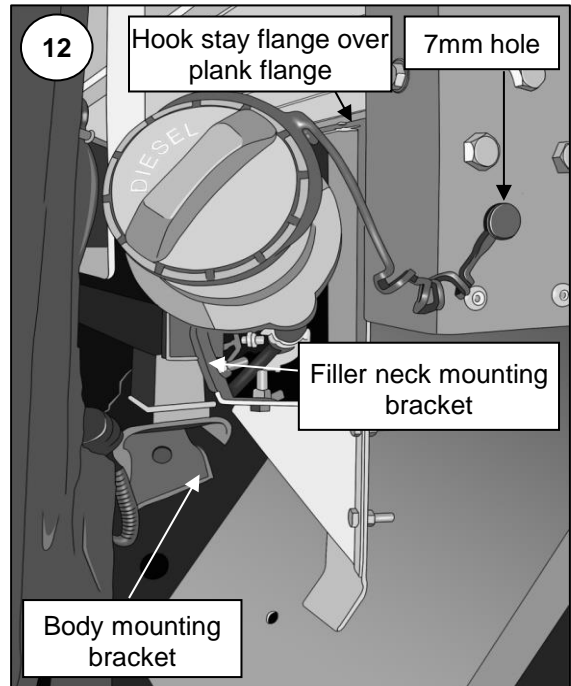

**NOTE:** Diagram 13a is shown for DC 2WD Hi-Rider (Chassis & Pick-Up Well Body Removal) and DC 4WD (Chassis & Pick-Up Well Body Removal).

- 23 Attach both **MFLP310** mud flaps to the mudguards using 4 of **SCRHHSS620** & **NUT6N** as well as 2 of **STRAP200** as shown in the diagram below.

**Note:** Diagrams only show one side and requires only 2 bolts, washers, nuts and 1 strap **ILL 13a,13b**.

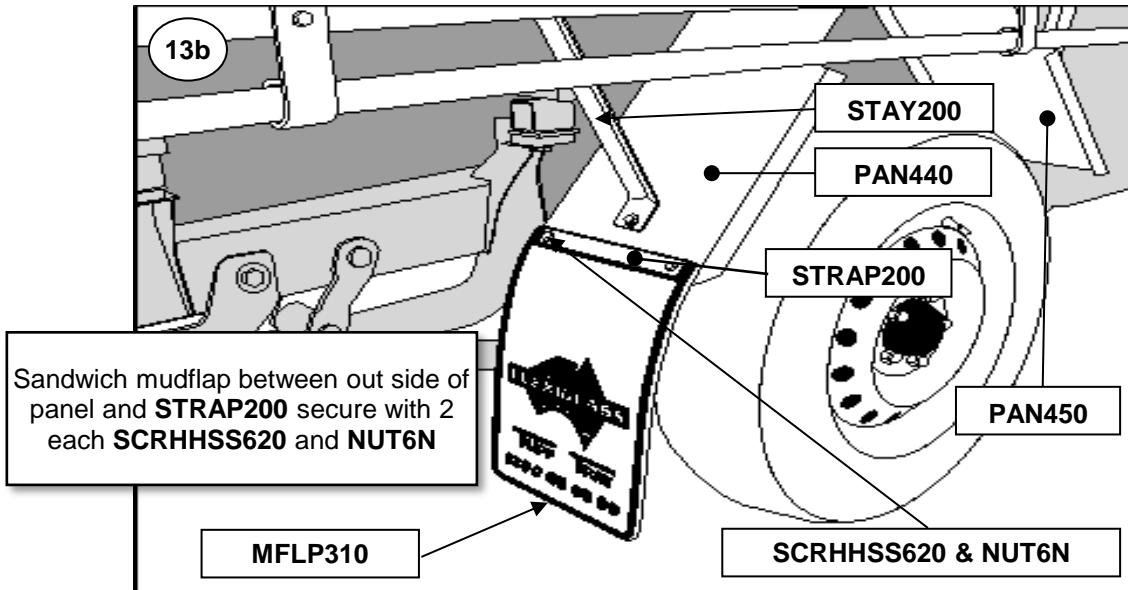

**NOTE: Diagram 13b is shown ONLY for DC 2WD (Pick-up Well Body Removal).**

- 24 Attach the two vent tubes to the underside of the tray wherever possible as in ILL 14.

**Note:**

On XLT models the license plate mount and lights are integral with the rear bumper, therefore re-fit the bumper bar to the tow bar in the reverse of **Item 10** of the **Well body removal** instruction below and omit **Items 25 & 26**.

- 25 Fit the vehicle licence plate lamps into the apertures provided in the **BKT660** and secure with the four **SCRPHSS416 & NUTSSM4** provided. See ILL 15.

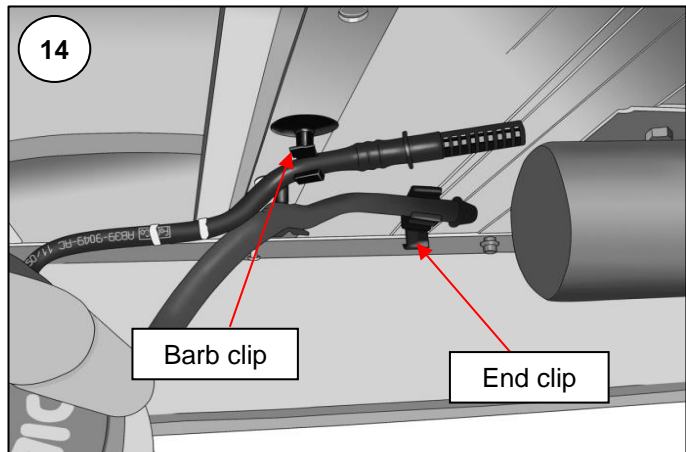

- 26 Attach **BKT660** Number plate bracket in the centre at the rear end of the tray as far to the rear as possible. Use 4 of M6x20 SS bolts and M6 Nylock nuts to fit to the underside of tray.

**Important:** BKT660 Number plate bracket must be fitted to the rear end of the tray to meet ADR requirements (as shown in the image).

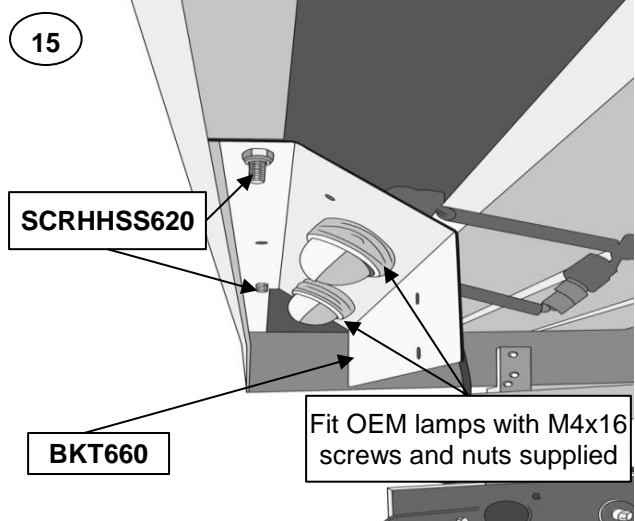

## ELECTRICAL WIRE STRIPPING SAFETY PROCEDURE

It is Flexiglass policy that the use of combination electrical cutting/crimping and stripping pliers be restricted to cutting and crimping use only.

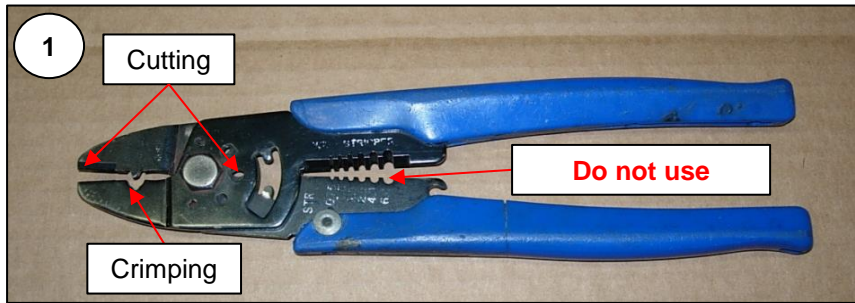

It is a documented fact that the use of these pliers can cause personal injury due to the fact that they are reliant upon holding the cable in one hand while pulling with the pliers with the opposite hand. Any attachments to the gripped end can be pulled into and through the palm of the gripping hand causing injury.

The single hand action strippers are to be used at all times for stripping cable ends ready for joining or connecting.

Two types of cable strippers are recommended, one operates with the pliers at 90° to the cable (2) the other operates in-line with the cable (3).

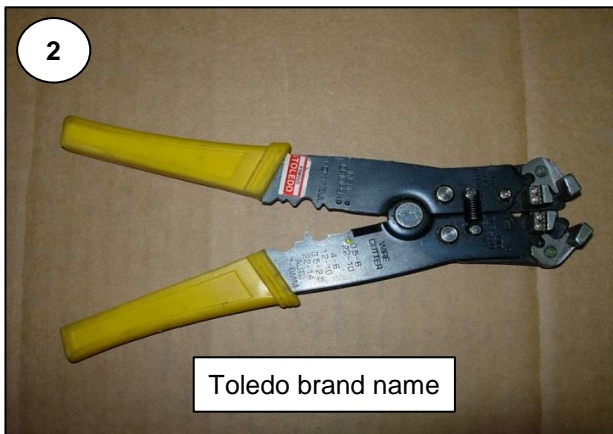

The tool in ILL 2 is a generally stronger and harder wearing item but the other is very useful for getting to cables in restricted space, it is therefore recommended that both types be available.

## OPERATING INSTRUCTIONS

- 1 Squeeze handles sufficiently to bring the lever jaws together. Lay cable between stripping jaws as shown in ILL 4.

**Note:**

There should be no necessity to strip more than 10mm of sheathing from the cable end for any of the connectors used by Flexiglass. If for any reason a longer stripped end is required, do it in repeated 10mm bites, the pieces can then be slid off the end using the fingers.

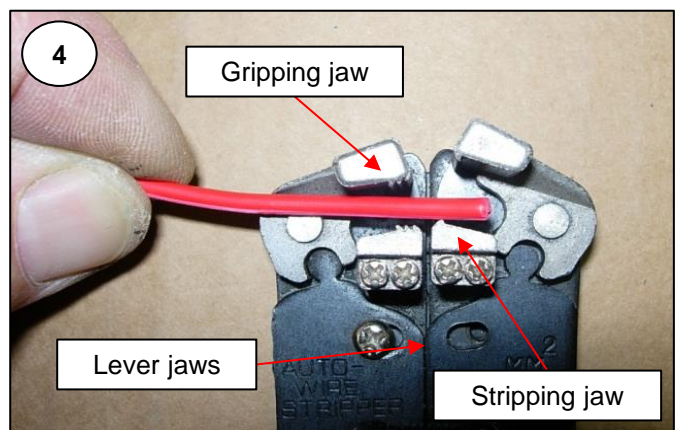



- 2 Continue squeezing the handles together to engage the gripping and stripping jaws.

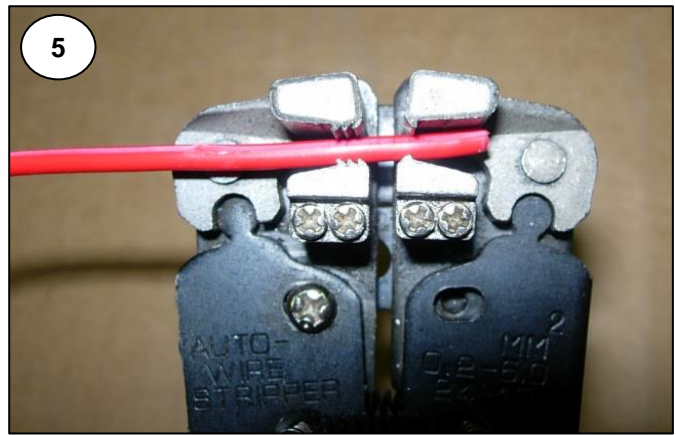

- 3 Increase the pressure slightly as you continue to squeeze. The stripping jaws will then move independently of the pliers cutting and stripping the end of the wire until with a sharp click both sets of jaws will automatically disengage.

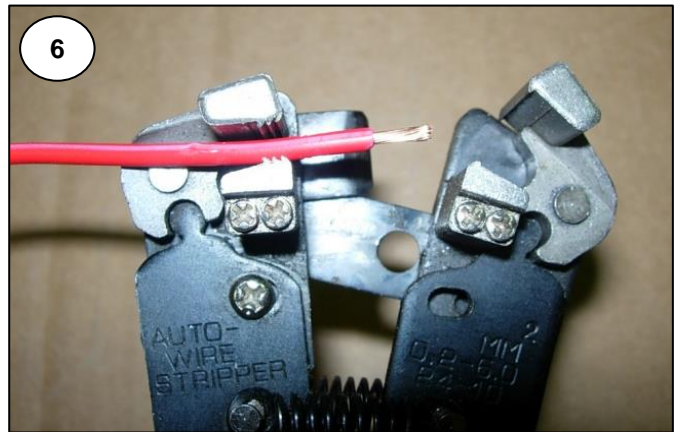

- 4 The Wurth pliers are simpler in operation. After placing the cable in the "V" of the bottom jaw, **ILL 7**, squeeze the handles together. The squeezing action brings the jaws together and forces the bottom jaw forward both cutting and pulling the sheath from the cable. See **ILL 8 & 9**.



**FIT INSTRUCTIONS (cont...)**

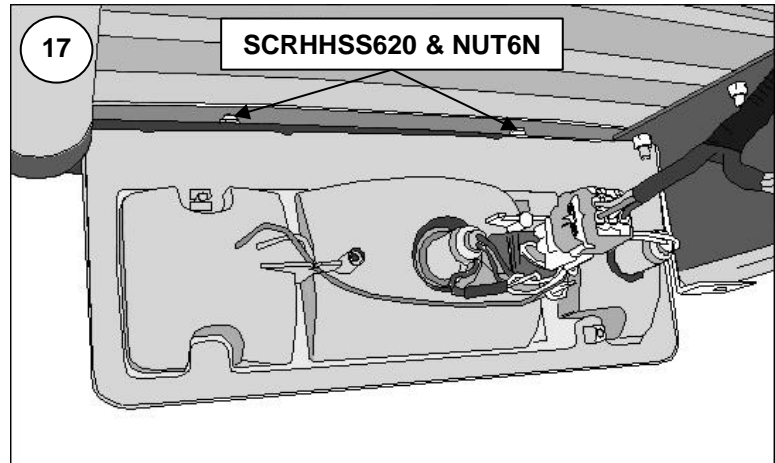
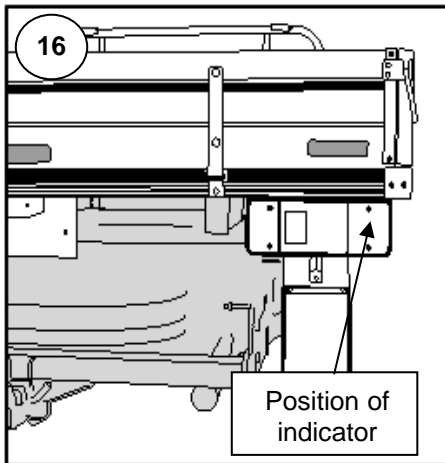

- 26 The OEM lamps and brackets should now be attached to the underside of the tray rear, ensure that the lenses are fully exposed and the indicator lenses are to the outside. See **ILL 16**.
- 27 All rear lamps can now be re-connected to the main harness using the original multi-pin snap connectors, check for correct operation.
- 28 Restrain loose electrical cables by tying to bearers, cross bars etc with the **TIE100** supplied.
- 29 If alterations to the wiring need to be made it is recommended that you consult an auto electrician first.
- 30 Detail and clean the tray for delivery to the client.
- 31 The OEM tail lamps and brackets should be lowered using **NUT10N & BLTHHZP640**. See **ILL 18**

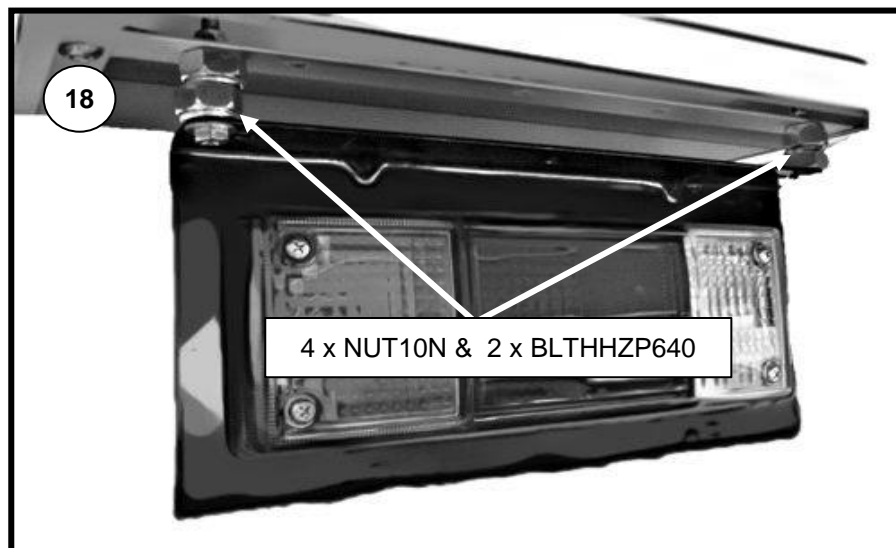

## WELL BODY REMOVAL

The model for this instruction was an XLT version with remote power supply on the rear of the passenger side wheel arch, tow bar pack and reversing sensors.

- 1 On the passenger side of the vehicle remove all the plastic screw/snap fixings around the plastic splash guard. See **ILL 19**.
- 2 Pull the guard down onto the wheel to give access to the filler (the guard cannot be entirely removed due to a pair of metal rivets at the rear of the wheel well).

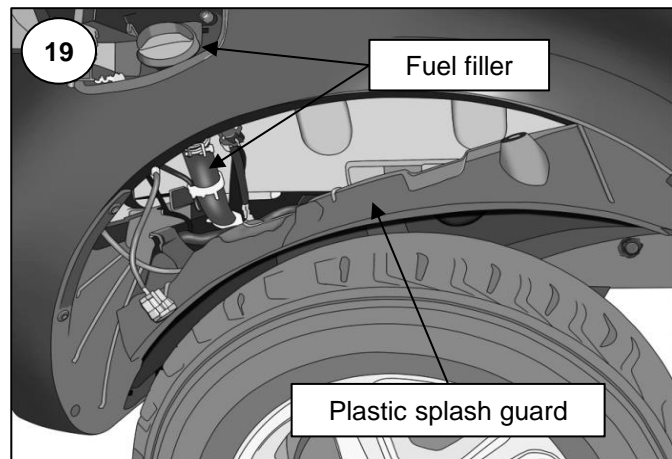

- 3 Inside the body panel just below the rubber, filler spill cup is a large multi connector, disconnect the plug from it. See **ILL 20**.
- 4 A small rubber hose can be found venting just under the filler cap in the spill cup, pull this out of the cup.
- 5 Using an 8mm socket undo the securing screw holding the filler neck to the body.
- 6 From beneath the vehicle, disconnect the rear remote power socket by unplugging the multi connector at the rear of the passenger side wheel arch.
- 7 Beneath the passenger side rear corner disconnect the reversing sensors, licence plate lamps and passenger side tail lamp cluster at their respective multiconnectors.
- 8 Beneath the driver side rear corner disconnect the tail lamp cluster wiring.

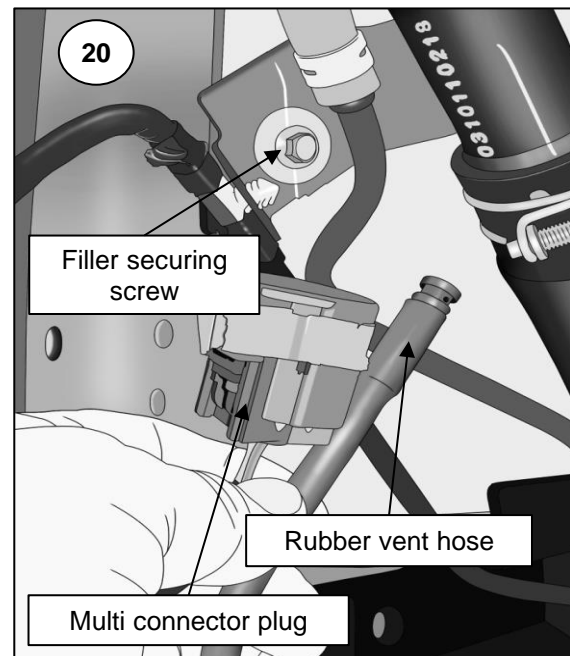

- 9 Beneath the driverside rear cabin corner, between the cab and tub, disconnect the multiconnector for the sports bar high level brake lamp. Ensure that any cable restraints attaching the tub or rear bumper wiring to the chassis are removed.
- 10 The bumper is bolted to the tow bar with four set screws (18mm socket) the the front holes are open ended to ease location and fitting. Loosen all four screws, remove one of the rear screws then support the weight of the bar and remove the rear screw from the other side. The bar can then be slid rearwards from the two front screws leaving them in place.
- 11 The tub is secured to the chassis by six 13mm flange headed set screws, some of them will require quite long extension bars to access them. Remove all six screws.
- 12 Pull the filler neck rearwards into the wheel arch then lift the tub from the chassis, ensuring it doesn't damage the cab rear or hook up on items attached to the chassis.
- 13 All multi connectors that will not be reconnected once the tray has been fitted (rear remote power source and fuel filler security connector) should be thoroughly wrapped with insulating tape to prevent water ingress. At the same time the small rubber vent tube should be tied to the filler assembly so that the open end remains above the level of the filler.

Follow steps 1-24 to fit tray then proceed with the instructions below for the rear lighting.

**NOTES ON USE OF KIT920 FOR WBR FITTING:**

The tail lights in the **KIT920** are compatible with the monitored wiring system of this vehicle. The vehicle tail lamps should have the wiring cut beside the lamp so that the vehicle multi-connector can be re-used for connection once the Flexiglass tail lamps have been joined using **CON110**.

**14** Assemble the **BKT660** and **LAMP280** by following the three point instruction below.

**A** Dismantle the two parts of the lamp cover by undoing the two Phillips head screws. See **Photo 1**.

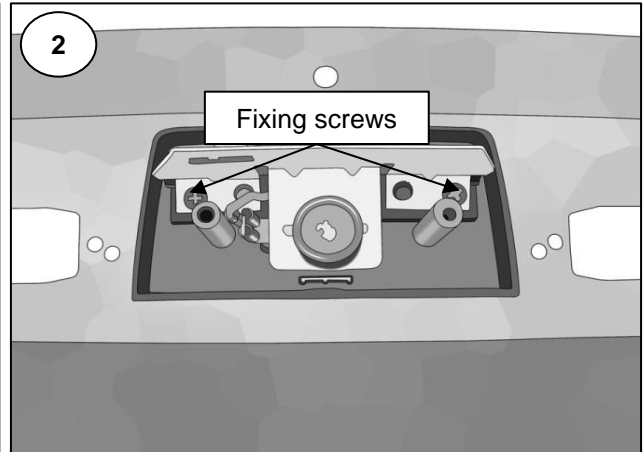
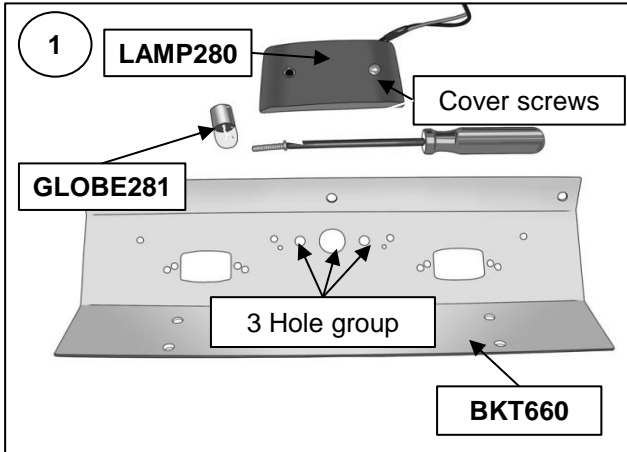

**B** Place the lamp base over the three hole group with the wires passing through the large central hole and fix using the two Phillips head self tapping screws provided. See **Photo 2**.

**C** Fit the light globe (supplied separately) into the holder then re-attach the cover and lens using the two screws removed in **Step A**.

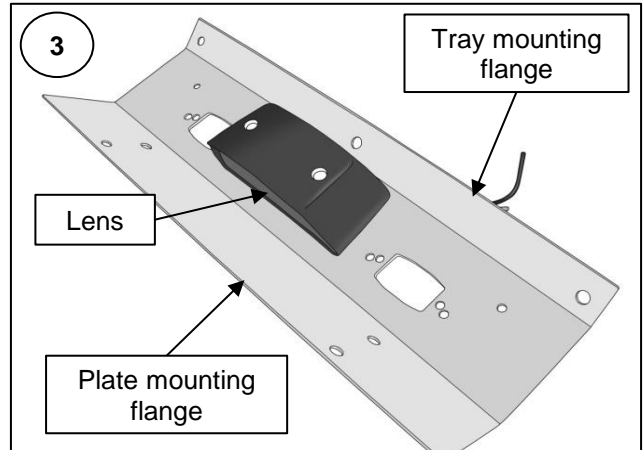

**15** Assemble the tail lamp clusters by following the instructions below.

**A** Use a 2 point Philips screw driver to remove the four lens securing screws and remove the lens. See **Photo 5**.

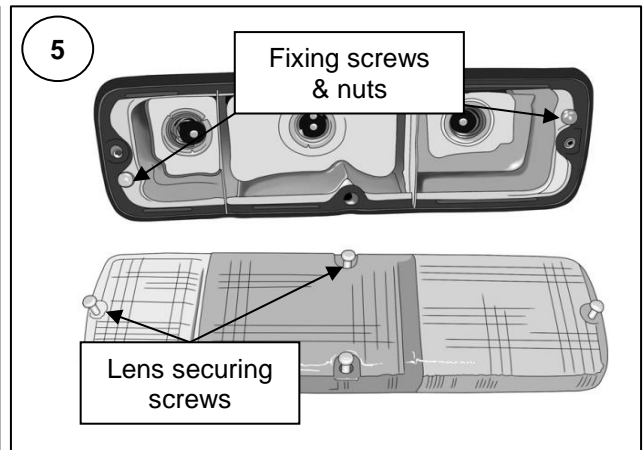
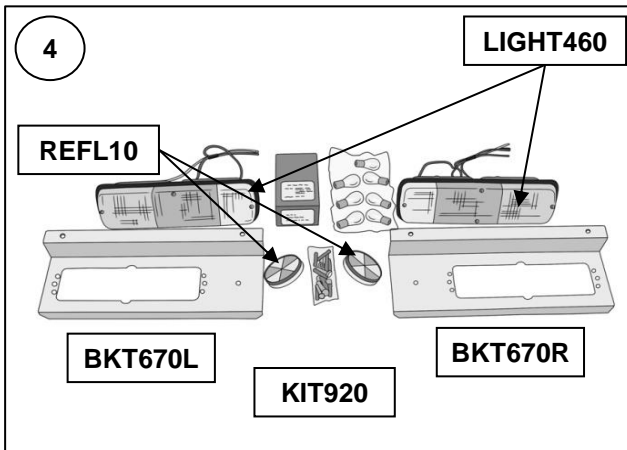

- B** Use the Philips screw driver and an 8mm spanner to remove the nut and washer from the lamp fixing screws. See **Photo's 5 & 6**.
- C** Insert the lamp body into the opening in the bracket and secure with the fixing screws nuts and washers.
- D** Fit the lamp globes into the sockets provided, the centre globe has double elements and staggered bayonet pins, do not mix it up with the other two. See **Photo 6**.

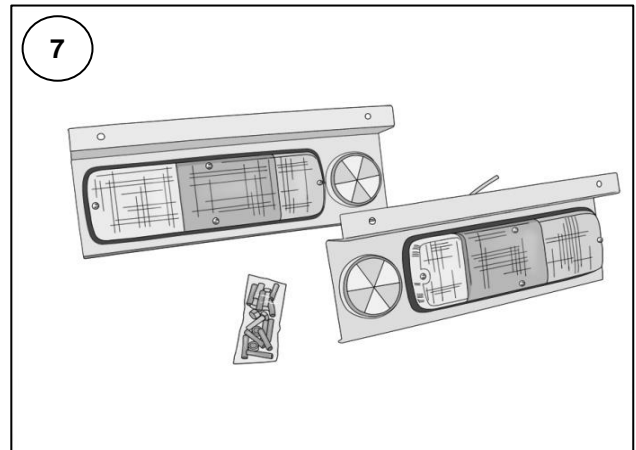
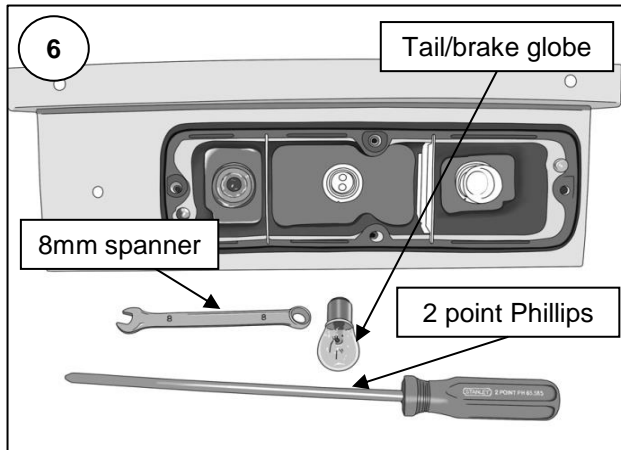

- E** Replace the lamp lens and secure with the four screws.
- F** Remove the flange nut (8mm) from the thread on the back of the **REFL10** insert the thread through the bracket, re-fit and tighten the nut to secure.
- G** Repeat for the opposite lamp assembly.

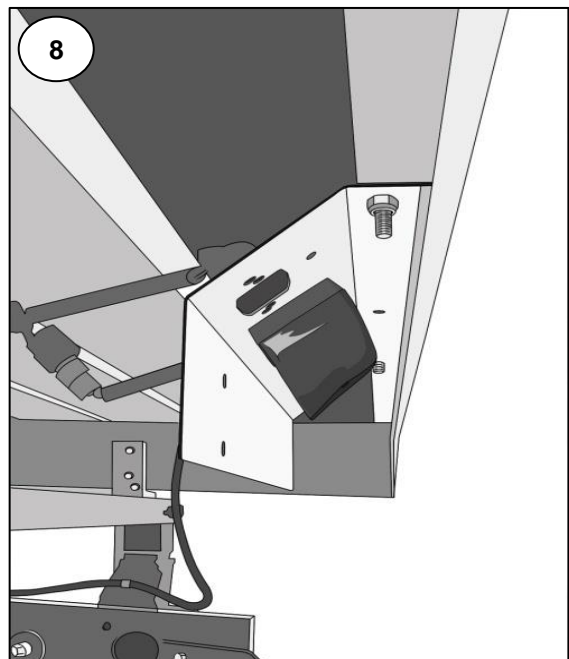

- 16** Attach the license plate bracket assembly to the underside of the rear plank as shown in **ILL 8** using two each **NUT6N & SCRHHSS620**.
- 17** Use the tail lamp bracket assemblies as templates to drill 1/4" holes through the rear of the rear tray plank. See **ILL 9**.
- 18** Use two each **SCRHHSS620 & NUT6N** to secure each bracket assembly as shown in **ILL 10**. Ensure that the reflector is positioned at the inboard end of the brackets. See **ILL 11**.

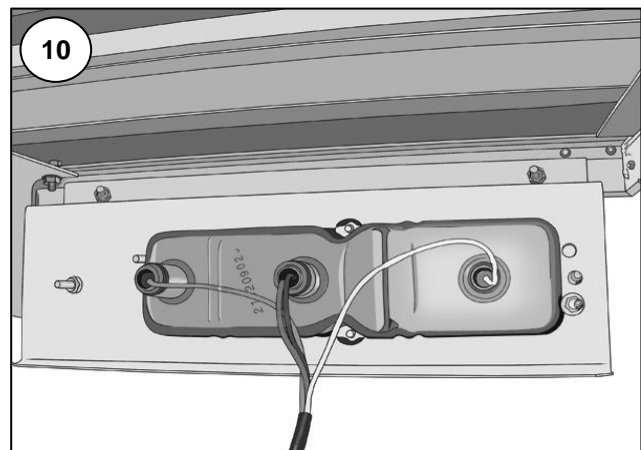
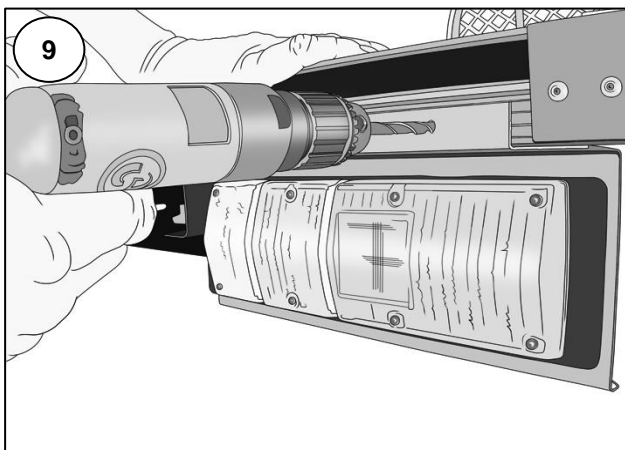

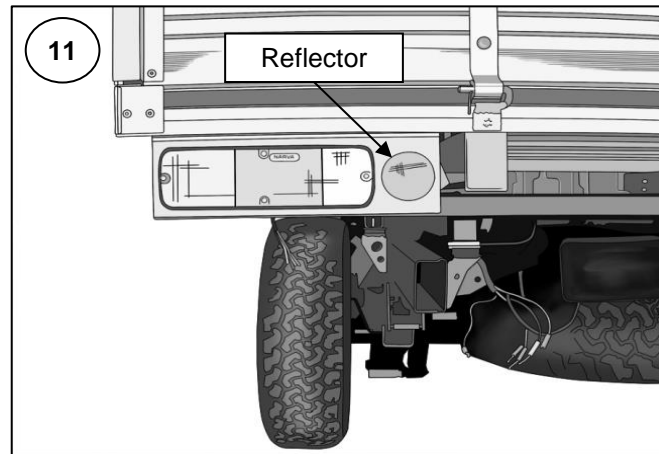

- 6 If the wiring, complete with multiconnectors, has been cut from the well body lights. Then the **LIGHT460**'s should be connected to it with **CON110** in the following manner.

Function	LIGHT460	PX Ranger Lights
Brake	Red	Green
Tail Lamp	Green	Red / Grey
Reverse Lamp	Blue	Red / Yellow
Indicator	Yellow	Green / Yellow
Earth	See below	Black

Attach an eye terminal to the earth line and clamp it under the **REFL10** securing nut. The tail lamps can now be re-connected to the main harness with the original multiconnectors.

- 7 If the tail lamps in the well body are not to be damaged then the multi connectors will have to be cut off and the main vehicle harness connected to the **LIGHT460**'s in the manner below with **CON110**.

Function	LIGHT460	PX Ranger Harness
Brake	Red	Purple / Brown
Tail Lamp	Green	Purple / Blue
Reverse Lamp	Blue	Green / Brown
Indicator	Yellow	Green
Earth	See above	Black / White

- 8 Connect the license plate lamp in the same manner as either of the methods given above.
- 9 Clean and detail tray as necessary for delivery to the customer.