



FLEXIGLASS FITTING MANUAL - SECTION 3.8C

FLEXIGLASS TRAY MAZDA BT-50 EC FIT - ISSA3

Note: Familiarise yourself with the instructions before you start to ensure you are clear on all aspects of the fit

SAFETY EQUIPMENT

- Hearing protection as required
- Eye protection as required

TOOLS REQUIRED

- Pneumatic / electric drill
- Pneumatic / electric hacksaw
- Drill bits: 21/64", 1/4" & 3/16"
- Sockets: 10, 13 & 18
- Toledo cable strippers
- Pneumatic driver
- Rivet gun with 5mm tip
- Loctite 243
- Wurth Cable strippers

These instructions will be suitable for the Flexiglass Deluxe Tray with the substitution of 4 of PAN500 mudgard panels in place of 2 each PAN440 & 450.

TRFITRMS Tray Fit Mazda BT50 SWB - Kit BOM				
Type	No.	Description	Quantity per	Unit of Measure Code
Item	BKT420	Bracket Fuel Filler	1	EACH
Item	BLK200C	Block For Cross Bars 40MM Coat	6	EACH
Item	BLTHHZP1290	Bolt & Nut Hex ZP 12X90mm	6	EACH
Item	NUT12C	Nut Channel M12	6	EACH
Item	NUT6N	Nut Nyloc M6	28	EACH
Item	NUT8N	Nut Nyloc M8	12	EACH
Item	PLT390C	Fish Plate forTrayBearers Coat	6	EACH
Item	RIVET200	Rivet 6-6 Steel	0	EACH
Item	SCRHHSS620	Screw Set Hex Head S/S 6x20mm	28	EACH
Item	SCRHHSS825	Screw Set Hex Head S/S 8x25mm	12	EACH
Item	SPACER30	Mounting Spacer 50 X 50 X 3	2	EACH
Item	SPACER40	Mounting Cross Bar Spacer	4	EACH
Item	SPACER50	Mounting Block Spacer 10MM	6	EACH
Item	SPACER60	Plastic Packer Spacer 4.5	0	EACH
Item	TIE100	Tie Cable BLK 4.8x300mm	6	EACH
Item	WSH220	Washer 5/16 X 3/4 Flat	12	EACH
Item	WSH10	Washer BRT Z/P 1/2x1- 7/8x14G	4	EACH
Item	WSH300	Washer Spring Z/P 12x2.5x2.5mm	6	EACH
Item	BAR310FC	Bar Universal Cross Mount Coat	3	EACH
Item	WSH240	Washer Brt Z/P 1/2x1-1/8x16G	8	EACH
Item	WSH180	Washer Brt Z/P 1/4x5/8x18G	4	EACH
Item	SCRPHSS416	Screw Philips Hd SS M4 x 16	4	EACH
Item	NUTSSM4	Nut SS M4	4	EACH
Item	TRSTDFITKIT	Tray STD Fitting Kit	1	EACH

- 1 Refer to **ILL 1** showing extended cab mounting positions. Locate these positions on the vehicle.
Note: All mount points on the vehicle must be used when fitting a Flexiglass Tray.
- 2 Refer to mount diagrams on **Page 3** which illustrates standard part usage for mounts on EC Mazda BT50 and Flexiglass Tray.
- 3 Fit the mounts in place on the chassis, using the parts and applying lock tight to thread as shown in the three diagrams on **Page 3**.

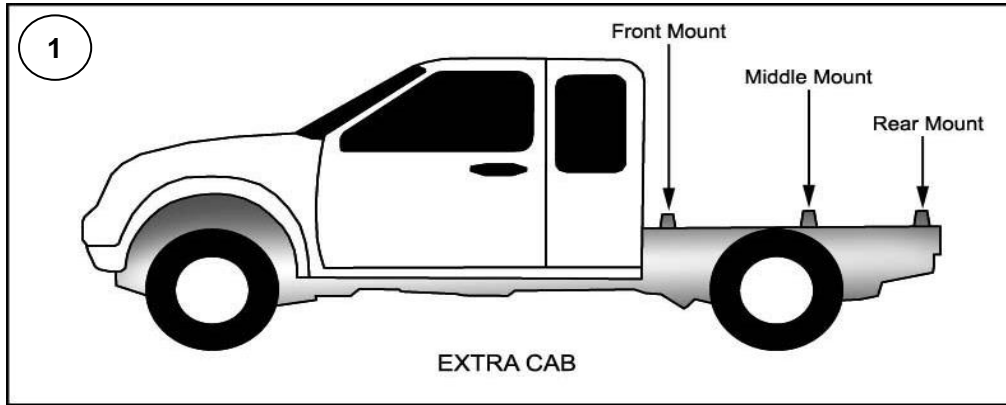

- 4 With all parts in place and the bolts still loose check the front and rear mounts are central over the chassis by measuring from the inside of one mount cleat to the inside of the opposite chassis rail. Repeat this for the other mount cleat and rail sliding the mounting cross bar "to and fro" until the measurements are equal. See **ILL 2**.
- 5 Tighten the four bolts securing the mount bars to the chassis mounts front and rear.
- 6 Place a length of **ALUM10** between the vertical faces on one side of the front and rear mounting cross bar cleats and clamp it to them. See **ILL 3**.
- 7 Slide the middle cross bar across until the cleats are against the same face of the angle as the front and rear cleats.
Note: This ensures that all three bars are now central and in line with each other.
- 8 Tighten the two bolts securing the middle mounting cross bar.

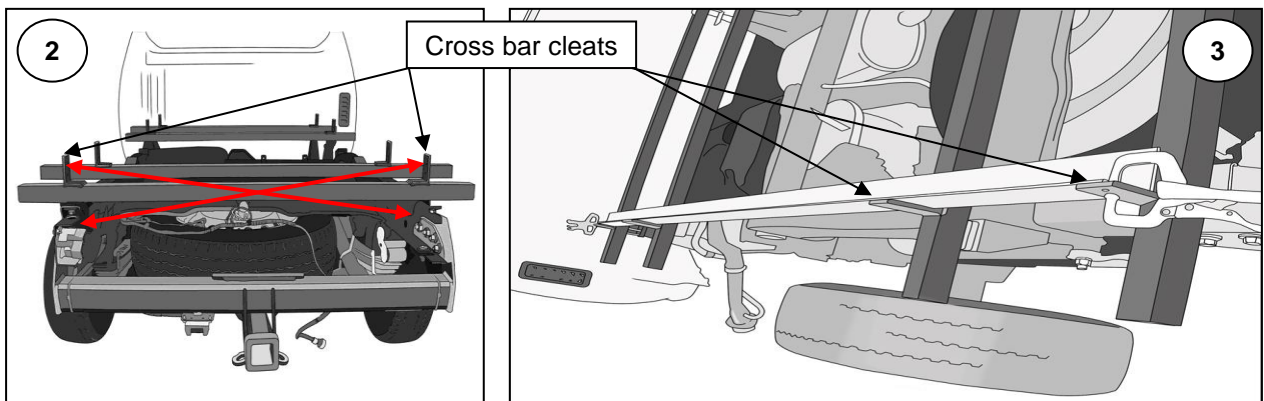

- 9 Place the Flexiglass Tray in place on the mounts.
Note: There must not be more than 700mm overhang of the tray bearers from the rear mounting position.
- 10 The front section (Z Bearer) of the tray needs to be a least 25mm back from the cab to allow for chassis twist.

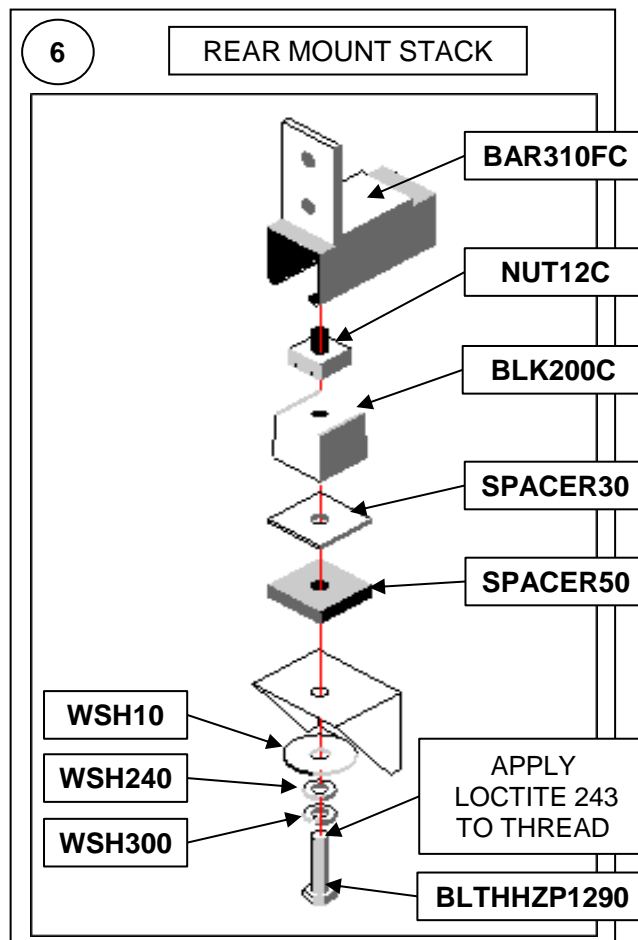
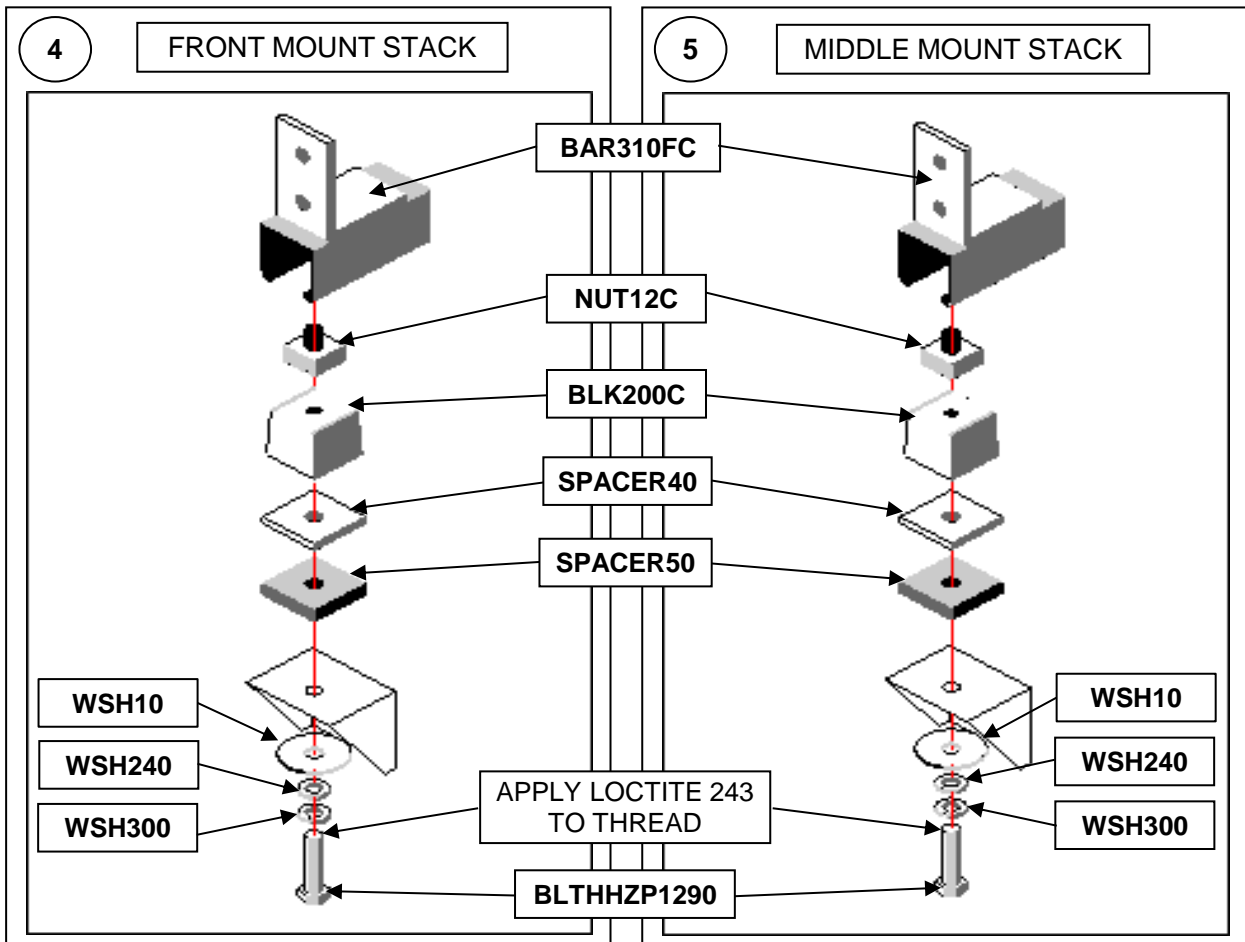

- 11 Once tray is lined up drill 21/64" Holes into the bearers using the mounting cross bar as a guide. See **ILL 7**.
- 12 Secure tray to the bearers as shown in the diagram right.
- 13 The stays are mounted to the mudguards in pre-drilled holes using 1 of **SCRHHSS620**, **WSH180** & **NUT6N**.

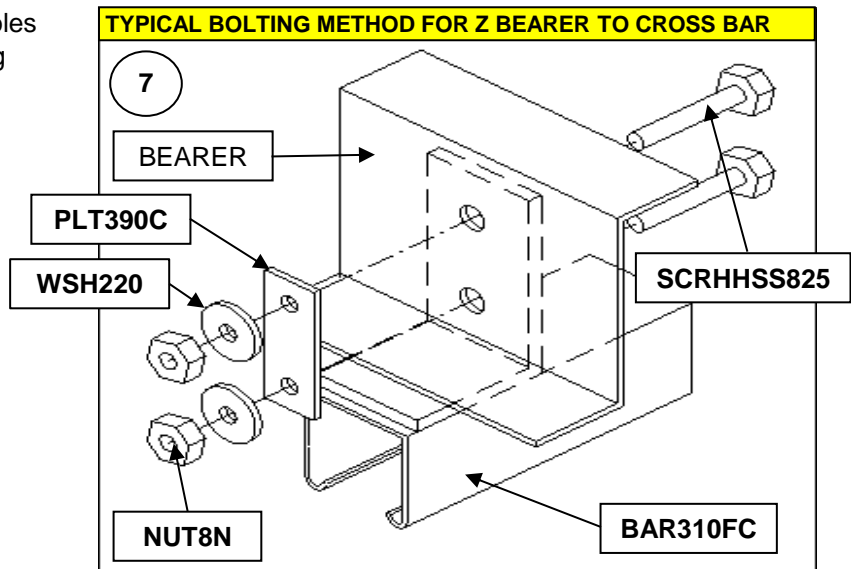

MOUNTING OF TWO PART MUDGUARDS

8

QTY Per TRAY		
SCRHHSS620	- M6 x 20mm SS HEX BOLT	20
NUT6N	- M6 NYLOC NUT	20
WSH180	- 6mm PLAIN WASHER	4
PAN440	- L/H 275mm MUDGUARD PANEL	2
PAN450	- R/H 275mm MUDGUARD PANEL	2
STAY200	- REAR MUDGUARD STAY	4
MFLP310	- MUDFLAP STANDARD	2
STRAP200	- MUDFLAP STRAP	2

- 14 Mount the mudguards to the underside of the tray deck by lining up the pre-punched holes in the mudguard with one of the ribs running along the underside of the tray. Drill 1/4" holes and attach with 2 of **SCRHHSS620** & **NUT6N**.
Note: Make sure the spacing between the mudguard and wheel is sufficient for both aesthetic and functional purposes. See **ILL 8** above.
- 15 Attach the other end of the stay to the underside of the tray using same method but with only one fixing.

STAY200 MODIFICATION

About 1/3 of tray fits will require a shorter mudguard stay than the **STAY200**, supplied, to accommodate fuel fillers etc. In those cases two of the **STAY200**'s will require modifying in the following manner.

- 1 Clamp the bottom end (large diameter hole) of the **STAY200** in a vice. See **ILL 1**.

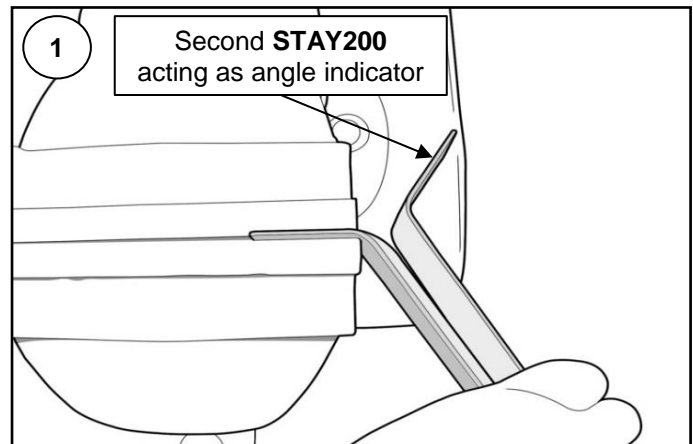

- 2 Use a second stay as a guide to straighten the bottom end, use the guide stay to achieve about 90° between the two ends. See **ILL 2**.

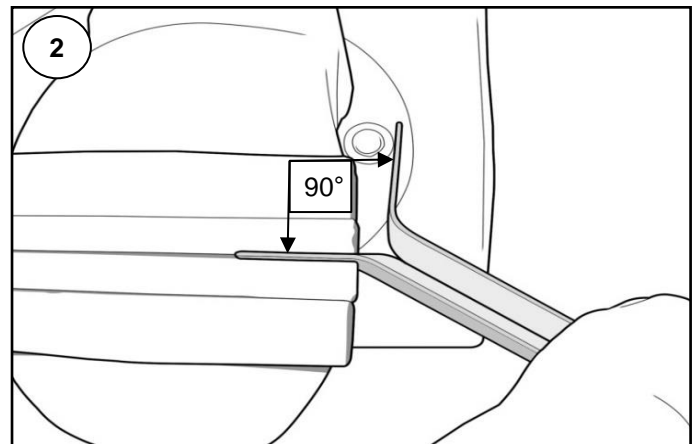

- 3 Measure from the inside of the bottom bend. About 255 - 260mm towards the top and make a mark.
- 4 Clamp the top end into the vice with the mark inside the end of the jaw. See **ILL 3**.

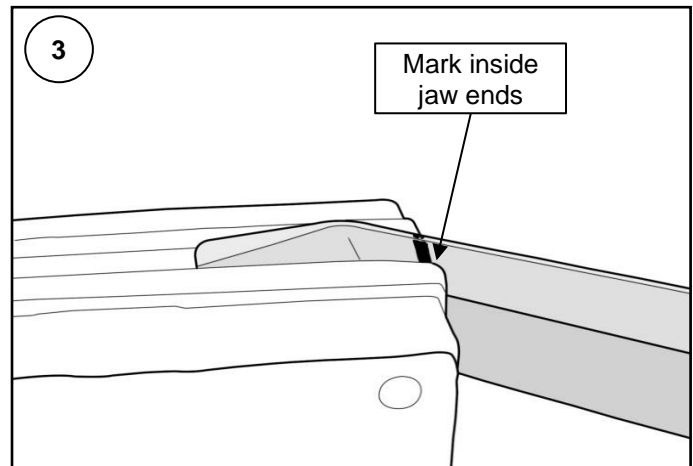

5 Press end flat by tightening vice jaws.
See ILL 4.

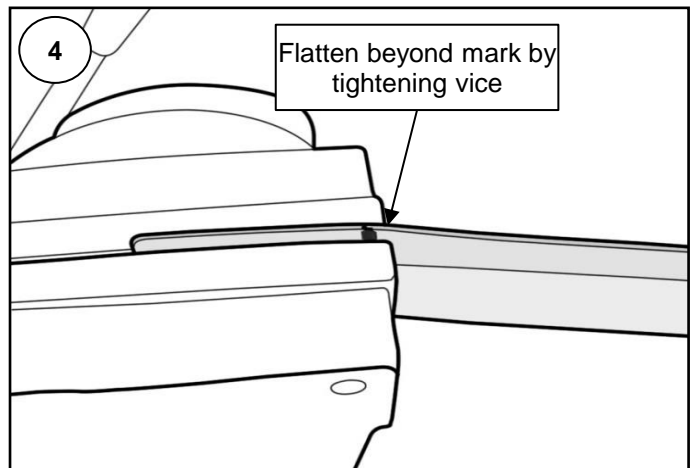

6 Lightly hammer the last bit of distortion out on the tightened jaws of the vice.
See ILL 5.

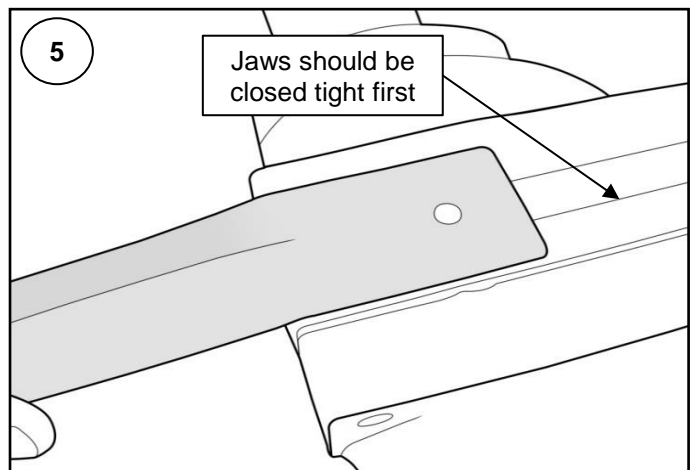

7 Clamp in the vice and bend the flattened end 90° at the mark to make the shape.
See ILL 6.

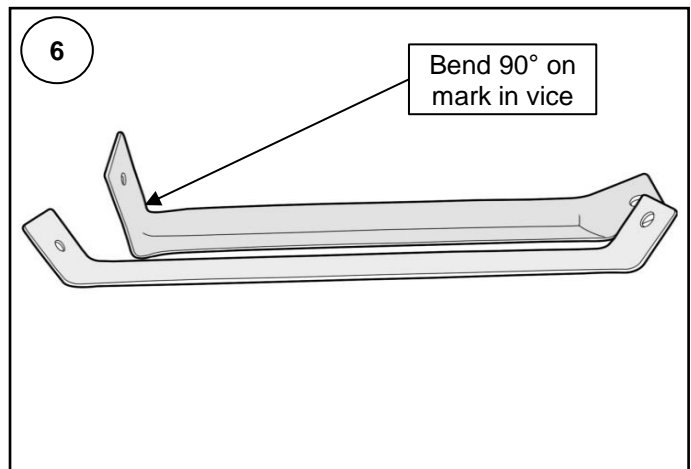

8 Shorten the newly bent end by about 30mm.
See ILL 7.

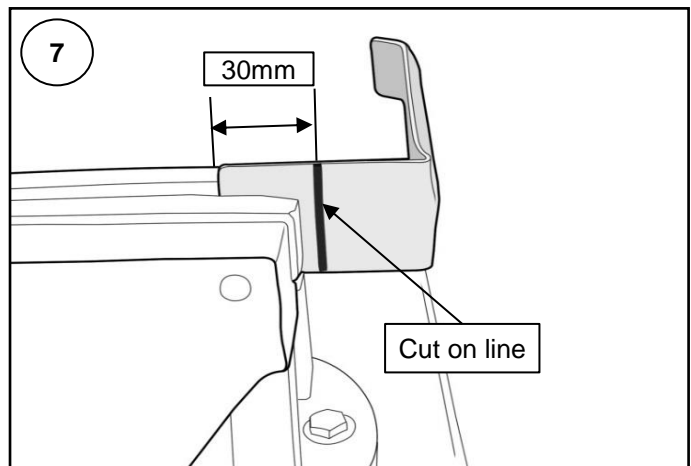

- 9 Drill a 1/4" hole in the middle of the new end.
See ILL 8.
- 10 Remove sharp edges and corners with a file.

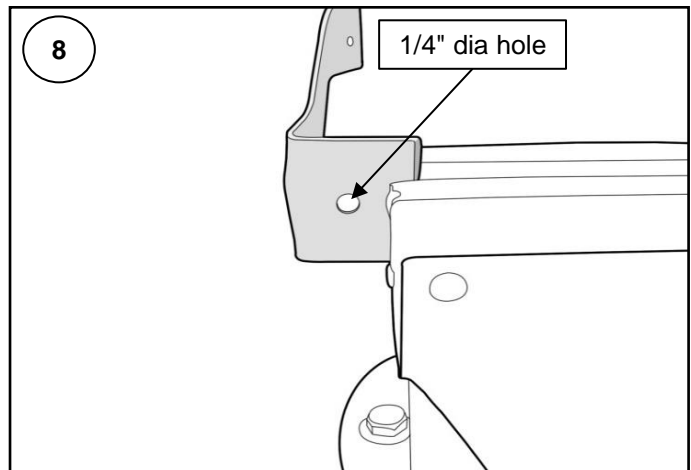

FIT INSTRUCTIONS (cont...)

- 16 Attach both **MFLP310** mud flaps to the mudguards using 4 of **SCRHHSS620** & **NUT6N** as well as 2 of **STRAP200**. See ILL 9.
Note: Diagram only shows one side and requires only 2 bolts, washers, nuts and 1 strap.

- 17 On the driverside of the tray, mark the rope rail about 30mm in front of the front side board hinge, cut through the rail at this point.

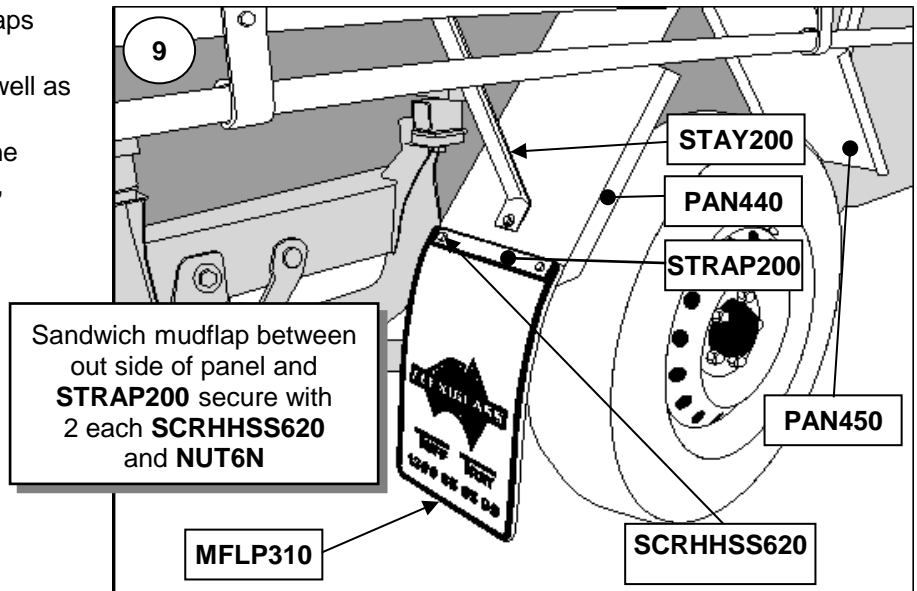

- 18 Drill out the rivets securing the cut piece to the headboard angle and discard. Fit new **RIVET200** to the vacant holes in the angle and fit a **CAP220** to the cut end of the rail. See ILL 11.

- 19 Bend about 80mm of the **BKT420** over to 90°, remove fuel filler cap and locate bracket and filler as shown in ILL 11, mark the screw hole positions on the bracket from the filler flange, remove bracket and drill holes.

- 20 Fit the fuel filler bracket, using the supplied nuts and bolts, ensuring no kinking of the rubber fuel pipe has occurred.

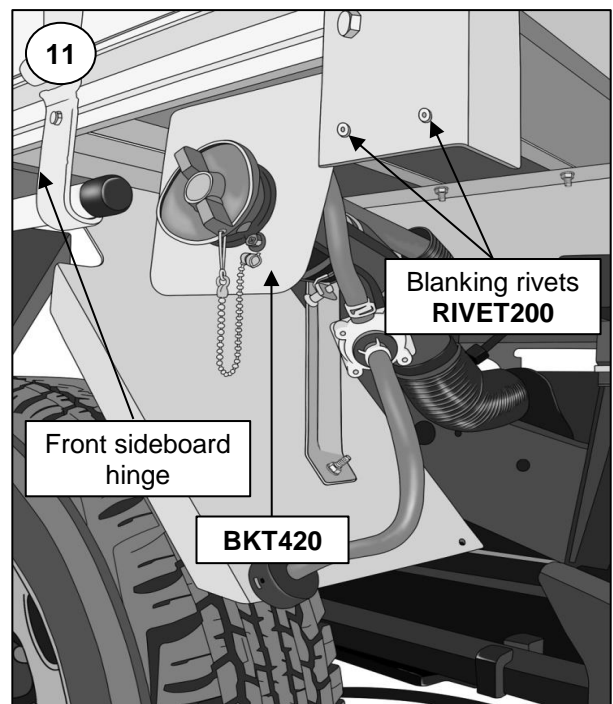

ELECTRICAL WIRE STRIPPING SAFETY PROCEDURE

It is Flexiglass policy that the use of combination electrical cutting/crimping and stripping pliers be restricted to cutting and crimping use only.

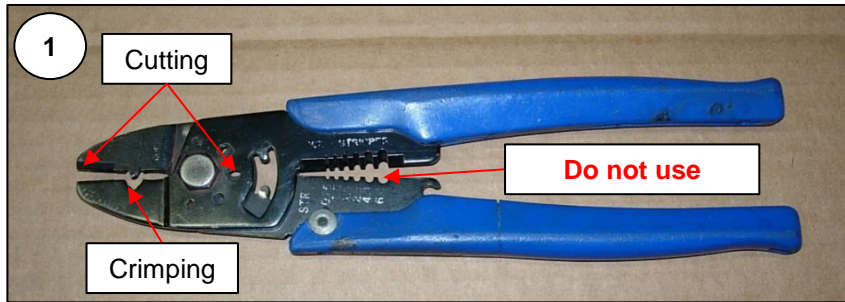

It is a documented fact that the use of these pliers can cause personal injury due to the fact that they are reliant upon holding the cable in one hand while pulling with the pliers with the opposite hand. Any attachments to the gripped end can be pulled into and through the palm of the gripping hand causing injury.

The single hand action strippers are to be used at all times for stripping cable ends ready for joining or connecting.

Two types of cable strippers are recommended, one operates with the pliers at 90° to the cable (2) the other operates in-line with the cable (3).

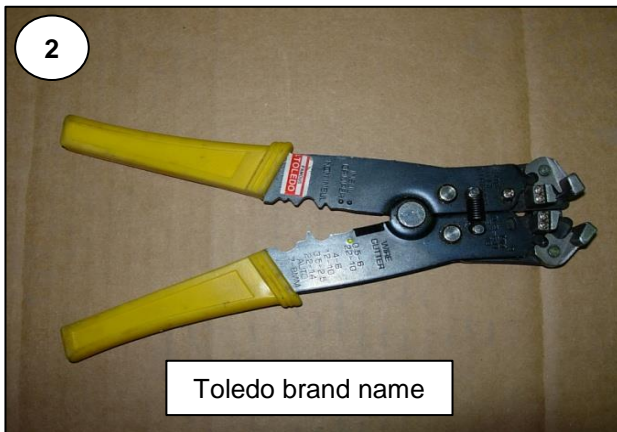

The tool in ILL 2 is a generally stronger and harder wearing item but the other is very useful for getting to cables in restricted space, it is therefore recommended that both types be available.

OPERATING INSTRUCTIONS

- 1 Squeeze handles sufficiently to bring the lever jaws together. Lay cable between stripping jaws as shown in ILL 4.

Note:

There should be no necessity to strip more than 10mm of sheathing from the cable end for any of the connectors used by Flexiglass. If for any reason a longer stripped end is required, do it in repeated 10mm bites, the pieces can then be slid off the end using the fingers.

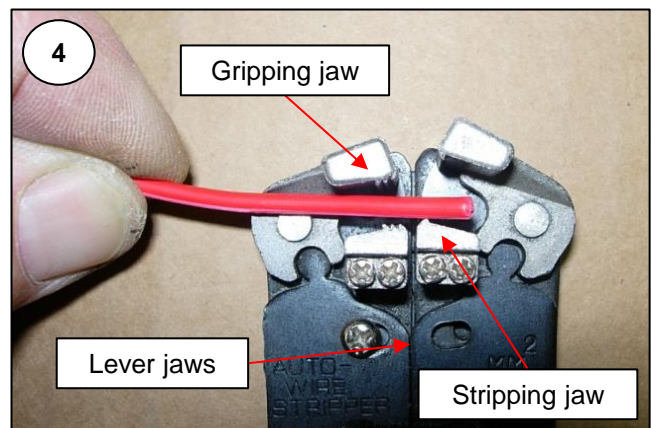

- 2 Continue squeezing the handles together to engage the gripping and stripping jaws.

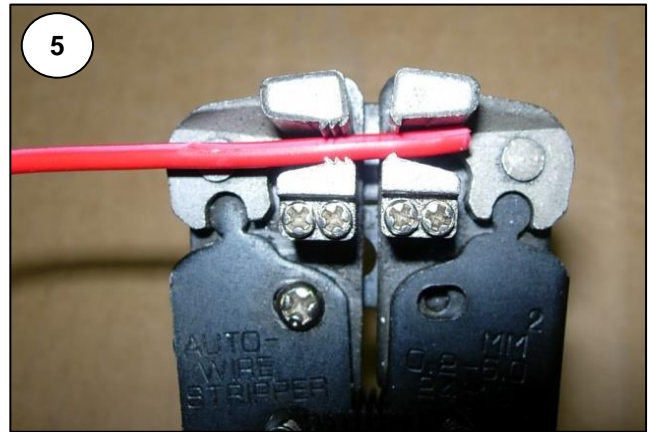

- 3 Increase the pressure slightly as you continue to squeeze. The stripping jaws will then move independently of the pliers cutting and stripping the end of the wire until with a sharp click both sets of jaws will automatically disengage.

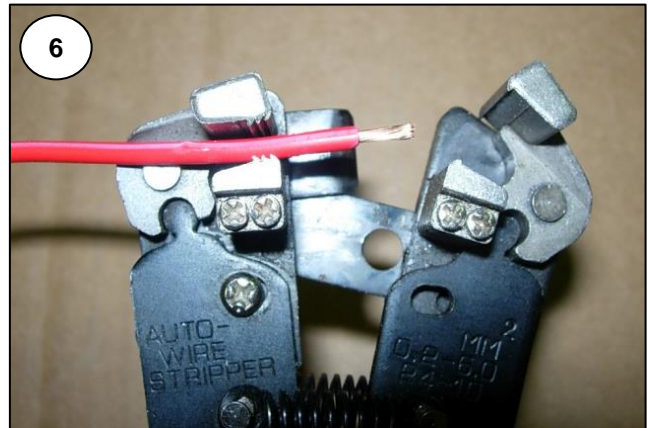

- 4 The Wurth pliers are simpler in operation. After placing the cable in the "V" of the bottom jaw, **ILL 7**, squeeze the handles together. The squeezing action brings the jaws together and forces the bottom jaw forward both cutting and pulling the sheath from the cable. See **ILL 8 & 9**.



FIT INSTRUCTIONS (cont...)

21 Fit the vehicle licence plate lamps into the apertures provided in the **BKT660** and secure with the four **SCRPHSS416** & **NUTSSM4** provided. See **ILL 12**.

22 Attach **BKT660** Number plate bracket in the centre at the rear end of the tray. See **ILL 12**. Use 4 of M6x20 SS bolts and M6 Nylock nuts to fit to the underside of tray.
Important: BKT660 Number plate bracket must be fitted to the rear end of the tray to meet ADR requirements (as shown in the image).

23 The OEM lamps and brackets should now be attached to the underside of the tray rear, ensure that the lenses are fully exposed and the indicator lenses are to the outside.

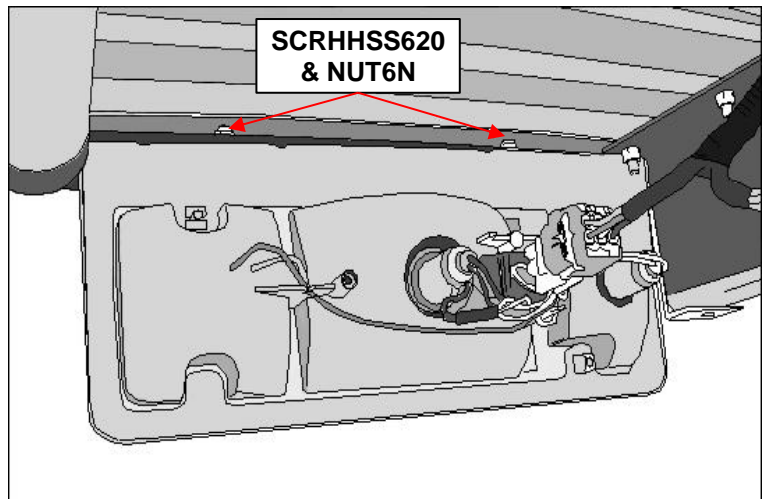
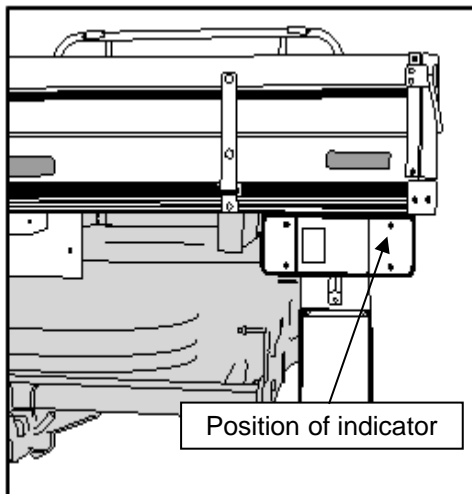
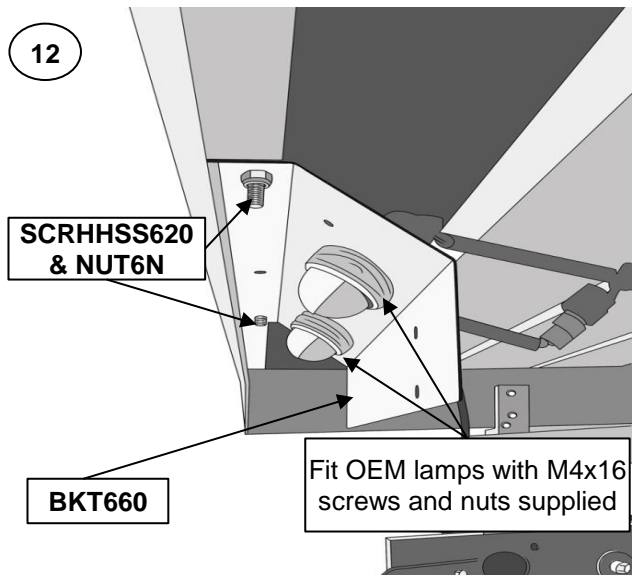

24 All rear lamps can now be re-connected to the main harness using the original multi-pin snap connectors.

25 If alterations to the wiring need to be made it is recommended that you consult an auto electrician first.

26 Detail and clean the tray for delivery to the client.