

FLEXIGLASS







5.2E - Side Steps Tray Fit

SAFETY EQUIPMENT

- Hearing protection as required
- Eye protection as required

TOOLS REQUIRED

- Pneumatic / Electric Drill(5,6&8mm) 
- Pneumatic / Manual Rivet Gun 
- Pneumatic/ Electric Hacksaw 
- 11R or 6R Vice Grips. 
- Pneumatic / Electric driver 

MATERIALS & PARTS REQUIRED

Part No.	Description	Qty.
A	Side Step Bracket	1
B	Side Step Tube	1
C	Bolt M6-40 ZP	2
D	Bolt M8-50 ZP	1
E	Nut Nylock N6	2

GENERAL NOTES

- Please read the fitting instructions prior to fitting the accessory.
- Install this accessory by following these fitting instructions. Please Note: Failure to follow these fitting instructions could result in damage to the vehicle and / or accessory.
- Recycle discarded components and packaging in accordance with the local regulations.
- Inspect the vehicle and note any damage or concerns found prior to accessory fitment. If there are any concerns contact the manufacturer before installing the accessory.
- If any damage or concerns are found that may interfere with the installation of the accessory, inform the customer prior to fitting the accessory.
- Ensure that you take care of and safely store any components that are removed from the vehicle.
- Ensure all bare metal surfaces are protected using an automotive bare metal primer and touch-up paint or suitable soft seal compound with rust inhibitor.
- Ensure any metal swarf or dust is carefully removed from all vehicle surfaces.
- Do not make any repairs or modifications to this accessory as it will void the warranty.
- Do not remove any of the accessory's labels.

WARNING

- Side Steps can not be fitted to Double CAB Tray and LHS of Super CAB Tray.

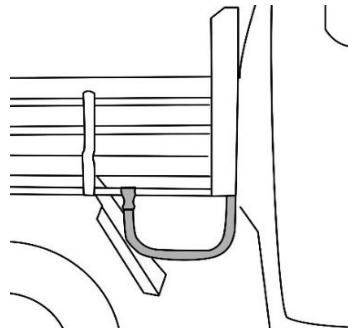

20 Mins



KIT140

ISSUE 1

16/04/2019

Page No : 1/3

1

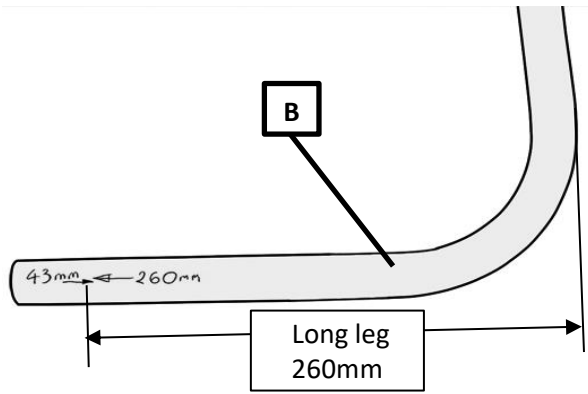

- Check the length of the long leg of the **B** (Side Step Tube) and if necessary trim it to an overall length of 260mm.



2

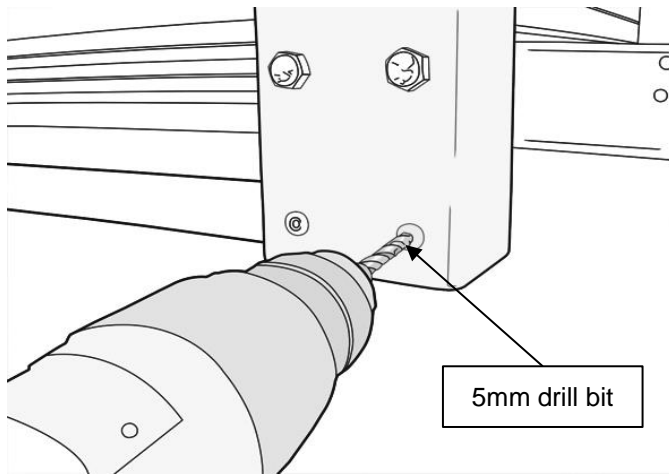

- Drill out the front rivet securing the rope rail with a 5mm drill bit.



3

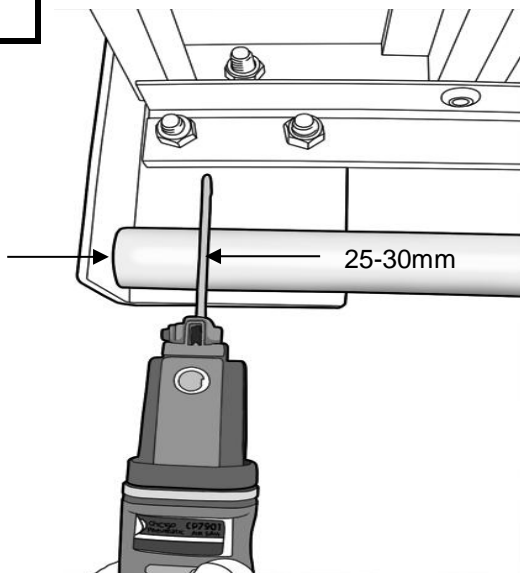

- Working beneath the tray deck, trim 25-30mm from the front of the rope rail. (Touch up any scratches on the headboard angle with zinc rich primer).



KIT140

ISSUE 1

16/04/2019

Page No : 2/3

4

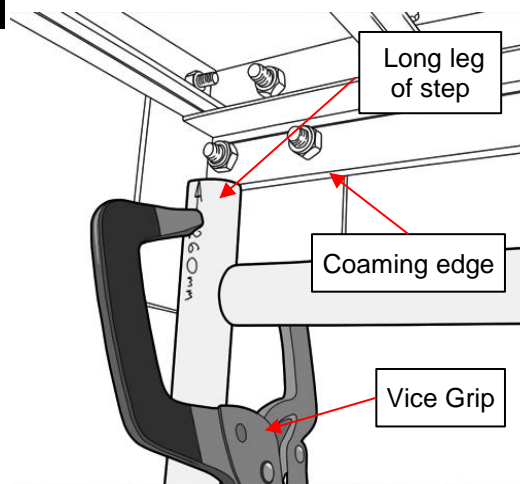

- Locate the step tube under the headboard angle in the gap cut in step 3. Ensure the end is hard up against the coaming edge and is pushed as far forward as possible. Clamp in position with Vice Grips making sure that the empty rivet hole in the angle can be reached with a drill later on.



5

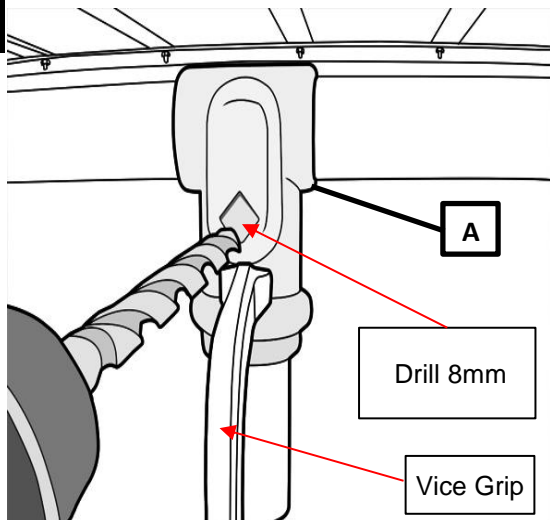

- Fit the two halves of the clamp **A** (Side Step Bracket) over the rope rail and around the shorter end of the step tube. Ensure that the step end is pushed hard up against the rail, then clamp in position with Vice Grips.
- Carefully drill an 8mm hole through the end of the step tube using the hole in the clamp as a guide.
- Fit **D** (Bolt M8-50 ZP) through the hole (head to the outside) and fully tighten.



6

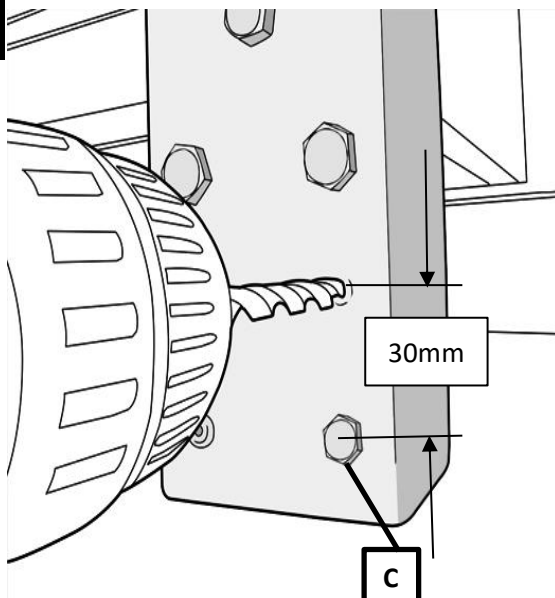

- With a 6mm drill open out the empty rivet hole from step 2 and drill the step tube behind it through both sides.
- Fit and tighten one of the **C** (Bolt M6-40 ZP) through the assembly.
- Remove the Vice Grips from the angle and about 30mm above the previous hole, drill another as shown in picture.
- Fit and fully tighten the other **C** (Bolt M6-40 ZP) bolt through this hole.



KIT140

ISSUE 1

16/04/2019

Page No :3/3