



5.2K - Tonneau Cover Double CAB Tray Fit

SAFETY EQUIPMENT

- Hearing protection as required
- Eye protection as required

TOOLS REQUIRED

- Pneumatic / Electric Drill 
- Pneumatic / Manual Rivet Gun 
- 4mm , 5mm drill bits 

MATERIALS & PARTS REQUIRED

| Part No. | Description | Qty. |
|----------|---------------------|------|
| A | Tonneau Cover | 1 |
| B | Tonneau Support Bar | 1 |
| C | Aluminium RopeTrack | 2 |
| D | Support Bar Sheath | 2 |
| E | Bar Brackets | 4 |
| F | Rivets | 43 |
| G | Lock Bracket | 1 |
| H | Rope Buttons | 27 |
| I | Dowel | 4 |

GENERAL NOTES

- Please read the fitting instructions prior to fitting the accessory.
- Install this accessory by following these fitting instructions. Please Note: Failure to follow these fitting instructions could result in damage to the vehicle and / or accessory.
- Recycle discarded components and packaging in accordance with the local regulations.
- Inspect the vehicle and note any damage or concerns found prior to accessory fitment. If there are any concerns contact the manufacturer before installing the accessory.
- If any damage or concerns are found that may interfere with the installation of the accessory, inform the customer prior to fitting the accessory.
- Ensure that you take care of and safely store any components that are removed from the vehicle.
- Ensure all bare metal surfaces are protected using an automotive bare metal primer and touch-up paint or suitable soft seal compound with rust inhibitor.
- Ensure any metal swarf or dust is carefully removed from all vehicle surfaces.
- Do not make any repairs or modifications to this accessory as it will void the warranty.
- Do not remove any of the accessory's labels.

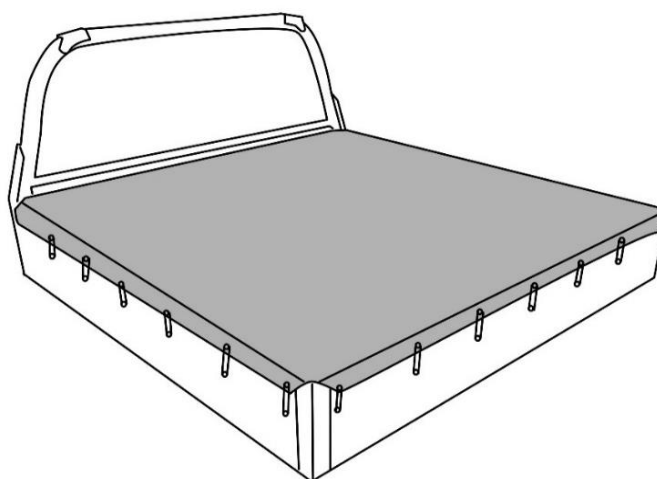

45 Mins



TONFPT03

ISSUE 1

16/04/2019

Page No : 1/3

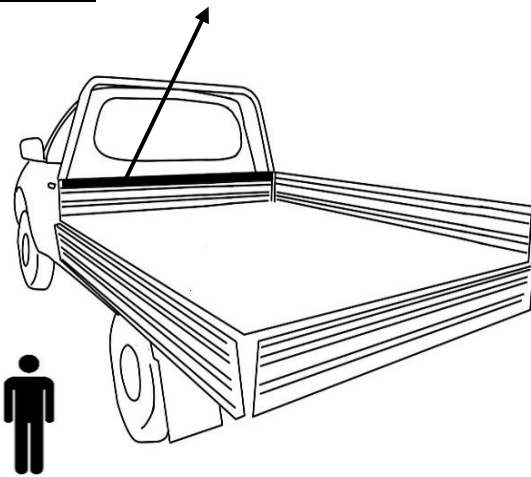
1**Front Vertical Edge**

- Join rope track pieces with dowel supplied. Place 1 piece of dowel in each end of the joined rope track.
- Place the rope track with dowel placed in the ends of the rope track on the top edge of the drop sides and push up against the front vertical edge of the tray. This is to ensure the rope track is at the correct height and the front bead of the Tonneau cover can slide through from the side.
- Using a 5 mm drill bit, drill six holes through the aluminium rope track and into the front face of the tray; one at 50mm from either edge, with the others evenly spaced between the outer two positions. Remove rope track and run a bead of silicone along the flat edge of the rope track, then rivet the aluminium rope track into position.

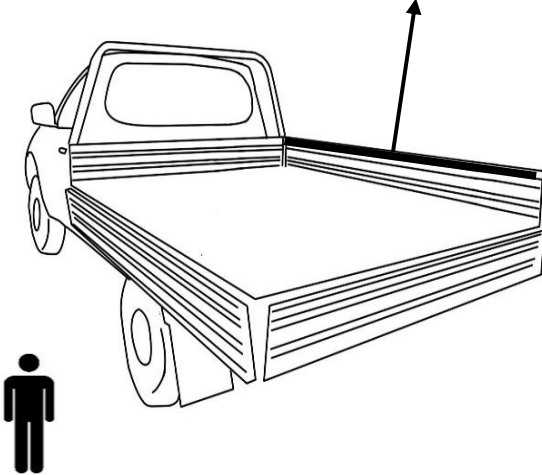
2**Top Edge of the Side of the Tray**

- To install your support bar. Measure the inside length of the tray. If you have been supplied **1** bar, halve this measurement and that is the support bar position. If you have been supplied **2** bars divide the measurement by 3 and these are the support bar positions. Centrally locate each bar bracket over these positions 5mm down from the top edge, drill and rivet the bar brackets into place. Repeat for the remaining bar brackets on both sides of the tray. Fit the Tonneau support bar/s to the bar brackets.
- Slide the front of the Tonneau cover through the aluminium rope track section. Neatly spread the Tonneau cover over the support bar/s, so it is centred and fully covers the tray.

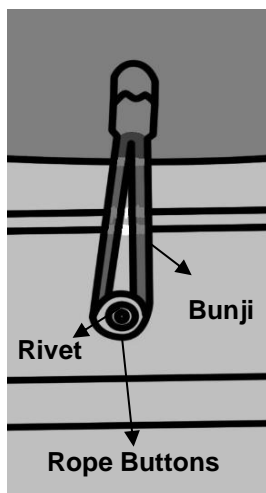
3

- To fit the rope buttons. Start with the rear centre bunjis (loops), ensure the Tonneau cover is **centred** and **taught (this is critical)**. Vertically line up each rope button individually to each bunji, squeeze the centre bunji loop together, with a marking pencil make a mark at the lower end of the bunji. This mark is the place to drill a hole and secure the first button with a pop rivet. Measure the distance between the top of the tailgate to the button and use this measurement to repeat the process for the remaining buttons on the tailgate, alternating from one side to the other. Secure the Tonneau cover to the tailgate using the bunjis as the rope buttons are fitted.



TONFPT03

ISSUE 1

16/04/2019

Page No : 2/3

4

●Note: if the side bunji nearest the front are the same length as the rest of the bunjis, the buttons should be fitted directly in line with the front bunji. If the side bunji nearest the front on each side of the Tonneau are longer than the side bunjis these buttons must be secured towards the front of the tray. For example, repeat the measurement down from top of the drop side and make a mark. From this mark, measure 65mm towards the front of the tray and mark this point. Drill and rivet the rope button and secure the Tonneau. Repeat this procedure for the other side of the tray.

Note: for Tonneaus with a front corner triangle sewn into the front LHS and RHS corners, repeat the above process to determine the height of the bunji. Place bunji where appropriate for specific vehicle.



Multi-Fit bar fitment;

●Insert solid bar pieces into either end of hollow tube. Adjust bar so it fits between bar bracket holders with the holes facing to the ground (so the grub screws don't rub against the tonneau), then with a white pencil make a mark through the small holes of the hollow bar onto the solid ends. This is where you will drill a hole to the depth of about 1-2mm (do not go any further)

●Join the pieces back together and screw grub screws through the hollow bar into the holes that you drilled. **Make sure you do not over tighten the grub screws.** Then place the tonneau sheath over the bar to stop the bar wearing against the tonneau. Refit the bar. You may kink the bar in the middle to give it some extra height to assist with water runoff.

Warning if you do not fit the tonneau sheath over the bar, the tonneau cover will quickly wear through which is not covered by warranty.



Tonno Lock;

●Attach the black lock bracket to the bracket on the tonneau with your padlock, and fit the tarp.

●Getting under the tarp with a torch, place the lock bracket against the body and mark holes with a pen.

● Remove tonneau and drill the marks with a 4 mm drill bit, place the lock bracket in position and rivet.



TONFPT03

ISSUE 1

16/04/2019

Page No : 3/3