

FLEXIGLASS





5.2Q - Under Tray Tool Box RHS Tray Fit

SAFETY EQUIPMENT

- Hearing protection as required
- Eye protection as required

TOOLS REQUIRED

- Pneumatic / Electric driver 
- Pneumatic / Electric Drill (6mm) 
- Pneumatic / Electric Hacksaw 

MATERIALS & PARTS REQUIRED

Part No.	Description	Qty.
A	Under Tray Tool Box	1
B	Bolt M6-50	4
C	Nut Nylock N6	4
D	Washer	4

GENERAL NOTES

- Please read the fitting instructions prior to fitting the accessory.
- Install this accessory by following these fitting instructions. Please Note: Failure to follow these fitting instructions could result in damage to the vehicle and / or accessory.
- Recycle discarded components and packaging in accordance with the local regulations.
- Inspect the vehicle and note any damage or concerns found prior to accessory fitment. If there are any concerns contact the manufacturer before installing the accessory.
- If any damage or concerns are found that may interfere with the installation of the accessory, inform the customer prior to fitting the accessory.
- Ensure that you take care of and safely store any components that are removed from the vehicle.
- Ensure all bare metal surfaces are protected using an automotive bare metal primer and touch-up paint or suitable soft seal compound with rust inhibitor.
- Ensure any metal swarf or dust is carefully removed from all vehicle surfaces.
- Do not make any repairs or modifications to this accessory as it will void the warranty.
- Do not remove any of the accessory's labels.

WARNING

- If Under Tray Toolbox is/will be fitted, the original mounting position of the Rear Ladder Rack must be changed. Please refer to Rear Ladder Rack Instruction.

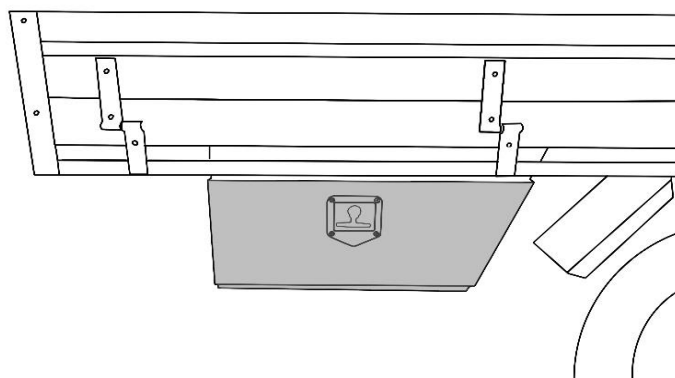

20 Min



BCTBU75R

ISSUE 1

16/04/2019

Page No : 1/3

1

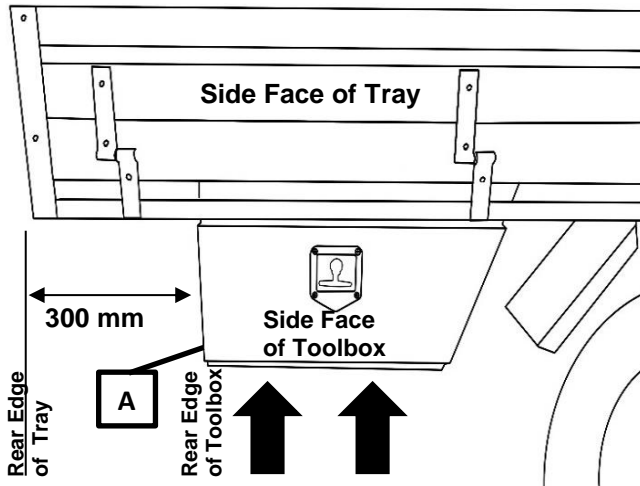

- Leave 300 mm distance between the rear edge of the tray and rear edge (straight edge) of A (Under Tray Toolbox)
- Side face of the A (Under Tray Toolbox) should be aligned with side face of the tray.
- Hold the A (Under Tray Toolbox) at the indicated position by using support



2

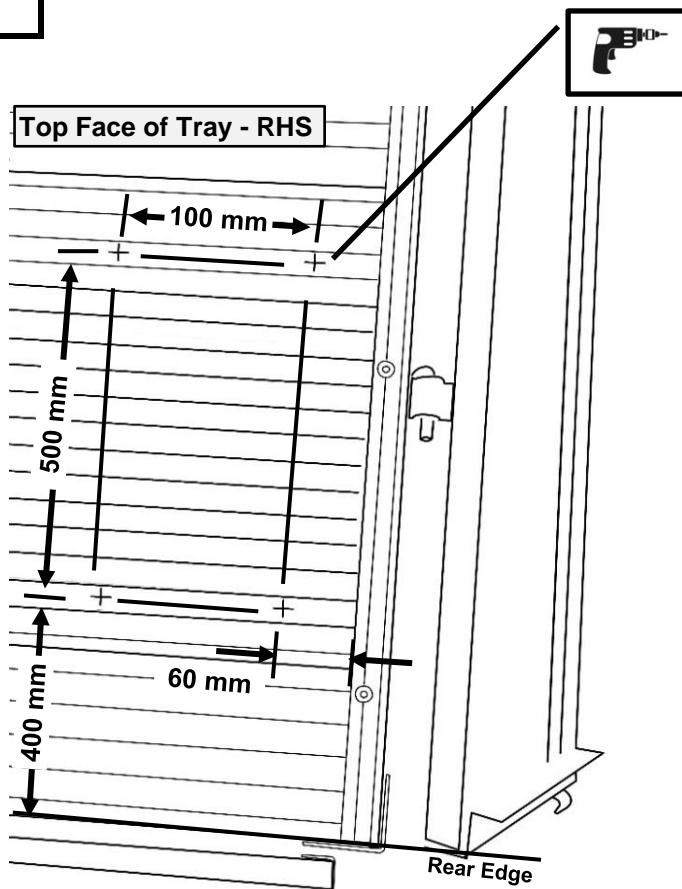

- Drill a 6mm hole on each marked position through the top face of the tray and the tool box.



BCTBU75R

ISSUE 1

16/04/2019

Page No : 2/3

3

Top Face of Tray - RHS

B

- Fit and fully tighten the **B** (Bolt M6-50) , **C** (Nut Nylock M6) & **D** (Washer)

4

Side Face of Tray

300 mm

Rear Edge of Tray

Rear Edge of Toolbox

Side Face of Toolbox

Mudguard Stay

- Due to the fitment position of the toolbox, Mudguard Stay needs to be trimmed and then fitted to the toolbox.

5

Side Face of Tray

250mm

Front Face of Toolbox

Mudguard Stay

New Mudguard Stay Measurements

100 mm

75°

45 mm

75°

45 mm

- After trim and bend the mudguard stay according to measurements above, drill 6mm hole and fit mudguard stay to the indicated position on the toolbox.



BCTBU75R

ISSUE 1

16/04/2019

Page No : 3/3